

Model CI-1040 12-Volt Automotive Deluxe Timing Light

HEATH COMPANY

BENTON HARBOR, MICHIGAN

MODEL **CI-1040 12-Volt Automotive  
Deluxe Timing Light**



**HEATHKIT®**  
**ASSEMBLY MANUAL**



Price \$2.00

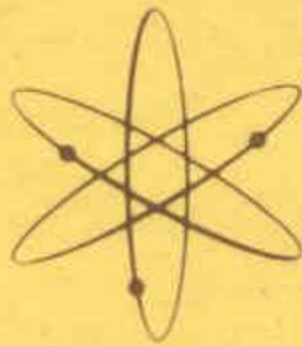

Copyright © 1972  
Heath Company  
All rights reserved

595-1466-03



Dear Customer:

The Heathkit electronic product you have purchased is one of the best performing electronic products in the world.

Here's how we aim to keep it that way:

### Your Heathkit Warranty

During your first 90 days of ownership, any parts which we find are defective, either in materials or workmanship, will be replaced or repaired free of charge. And we'll pay shipping charges to get those parts to you — anywhere in the world.

If we determine a defective part has caused your Heathkit electronic product to need other repair, through no fault of yours, we will service it free — at the factory, at any retail Heathkit Electronic Center, or through any of our authorized overseas distributors.

This protection is exclusively yours as the original purchaser. Naturally, it doesn't cover damage by use of acid-core solder, incorrect assembly, misuse, fire, flood or acts of God. But, it does insure the performance of your Heathkit electronic product anywhere in the world — for most any other reason.

### After-Warranty Service

What happens after warranty? We won't let you down. If your Heathkit electronic product needs repairs or you need a part, just write or call the factory, your nearest retail Heathkit Electronic Center, or any Heath authorized overseas distributor. We maintain an inventory of replacement parts for each Heathkit model at most locations — even for many models that no longer appear in our current product line-up. Repair service and technical consultation are available through all locations.

We hope you'll never need our repair or replacement services, but it's nice to know you're protected anyway — and that cheerful help is nearby.

Sincerely,

HEATH COMPANY  
Benton Harbor, Michigan 49022

Prices and specifications subject to change without notice.



Assembly and  
Operation of the



**12-VOLT  
AUTOMOTIVE DELUXE  
TIMING LIGHT  
MODEL CI-1040**



**HEATH COMPANY**  
BENTON HARBOR, MICHIGAN 49022

## TABLE OF CONTENTS

Introduction . . . . .	3	Specifications . . . . .	28
Parts List . . . . .	4	Theory of Engine Operation . . . . .	29
Step-by-Step Assembly		Circuit Description . . . . .	32
Circuit Board Assembly . . . . .	6	Circuit Board X-Ray View . . . . .	35
Wiring . . . . .	11	Schematic. . .(fold-out from page) . . . . .	35
Component Housing Assembly . . . . .	17	Identification Photograph . . . . .	36
Adjustments . . . . .	18	Warranty . . . . .	Inside front cover
Final Assembly . . . . .	22	Customer Service . . . . .	Inside rear cover
Operation . . . . .	24		
In Case of Difficulty			
Troubleshooting Chart . . . . .	26		



## INTRODUCTION

The Heathkit Model CI-1040 12-Volt Automotive Timing Light is a self-contained, solid-state flash unit that is powered by the vehicle battery and features an all new triggering method. An easy-to-hold, high-impact plastic housing is ideally proportioned to allow you to aim the Timing Light in narrow spaces while keeping your hand at a safe distance from moving engine parts. A special, easy-to-connect, low voltage trigger pickup coil even permits you to connect the Timing Light while the engine is running. This also eliminates direct connections to the spark plug.

The flash from this unit is many times brighter than the flash from timing lights that operate from only the spark plug voltage. This extra brilliance is created by a high voltage within the Timing Light. A solid-state inverter circuit, mounted on a circuit board, steps up the battery voltage to provide this high voltage. The professional, or the do-it-yourself auto mechanic, desiring professional tune-up equipment will find the high intensity flash a pleasure to use even under full daylight conditions.

Many other timing lights receive their triggering signal directly from the spark plug voltage. However, in this Timing Light, a portion of the spark plug current is inductively coupled into the pickup coil to provide the low voltage triggering signal. Also, because an indirect triggering method is used, the Timing Light does not interfere with other test instruments that may be connected to the engine.

A special, built-in neon lamp allows you to accurately adjust the high voltage circuit without using special instruments.

Information on how to use and maintain the Timing Light is supplied in this Manual. Essential facts about automotive ignition systems and an example procedure for engine ignition timing are explained in the "Operation" and "Theory of Engine Operation" sections on Pages 24 and 29.

Refer to the "Kit Builders Guide" for complete information on unpacking, parts identification, tools, wiring, soldering, and step-by-step assembly procedures.

# EXPEDITED PARTS ORDER FORM

(FOR REPAIR PARTS ONLY)

PLEASE DO NOT WRITE IN THIS SPACE

(1) Give Part Numbers as they are in parts list.

(2) Include remittance or permission for C.O.D. shipment.

CASH  C.O.D.

(3) Use separate sheet of paper for all correspondence.

(4) Prices may change to reflect current manufacturing costs.

(5) Current HEATH account number

AA

KIT MODEL \_\_\_\_\_

DATE OF PURCHASE \_\_\_\_\_

SERIES NUMBER \_\_\_\_\_

\_\_\_\_\_

QTY.	PART NUMBER	DESCRIPTION	PRICE	TOTAL PRICE	MARK PROPER SPACE FOR WARRANTY PARTS ONLY		
					3 DAMAGED	2 DEFECTIVE	1 MISSING

MARK PROPER SPACE FOR WARRANTY PARTS ONLY

3 DAMAGED 2 DEFECTIVE 1 MISSING

**HEATH COMPANY**  
 BENTON HARBOR  
 MICHIGAN 49022  
 PHONE 616-983-7381

NAME \_\_\_\_\_  
 ADDRESS \_\_\_\_\_  
 CITY \_\_\_\_\_  
 STATE \_\_\_\_\_ ZIP \_\_\_\_\_

## PARTS LIST

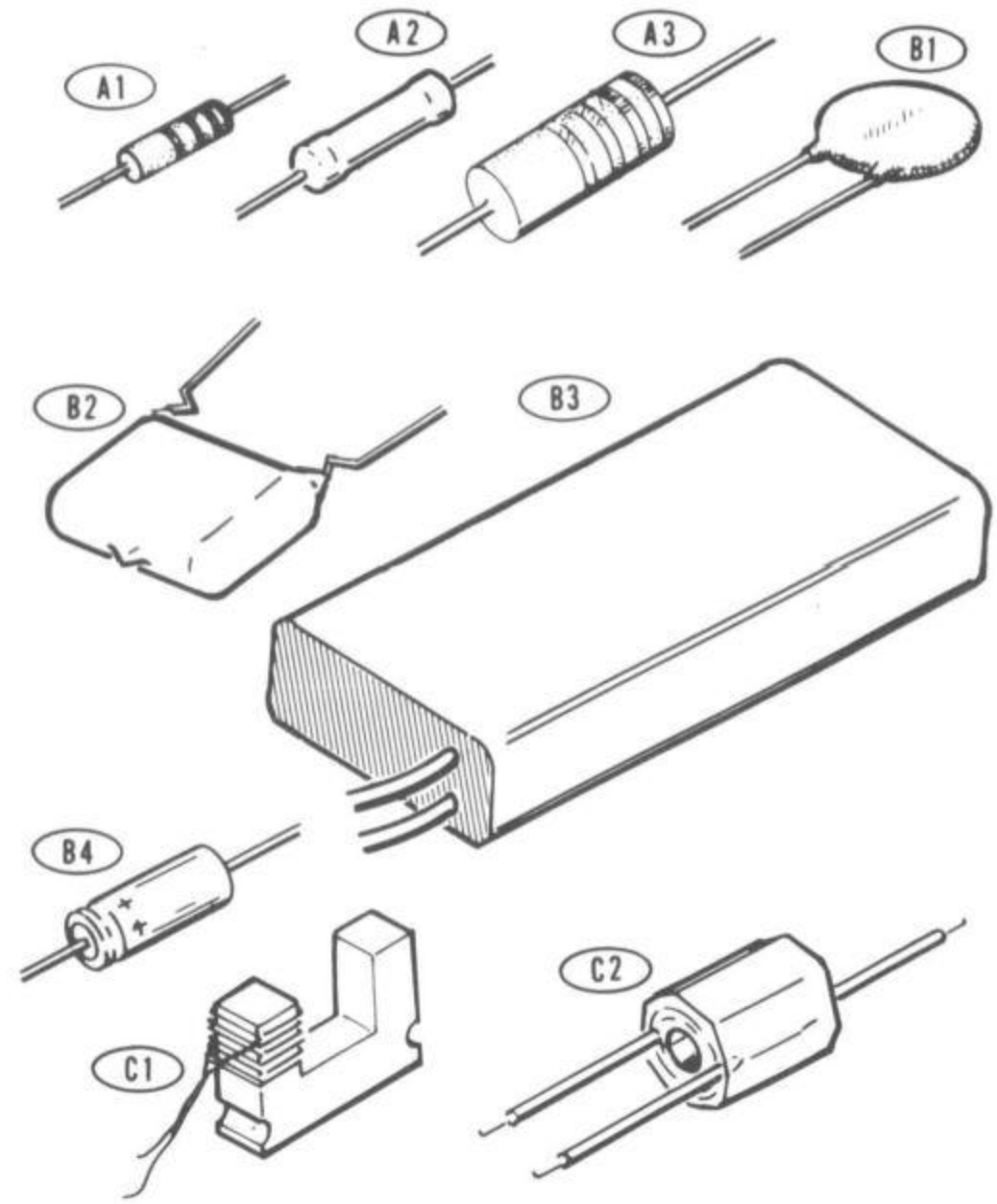

THIS FORM IS FOR U.S. CUSTOMERS ONLY. OVERSEAS CUSTOMERS SEE YOUR DISTRIBUTOR.

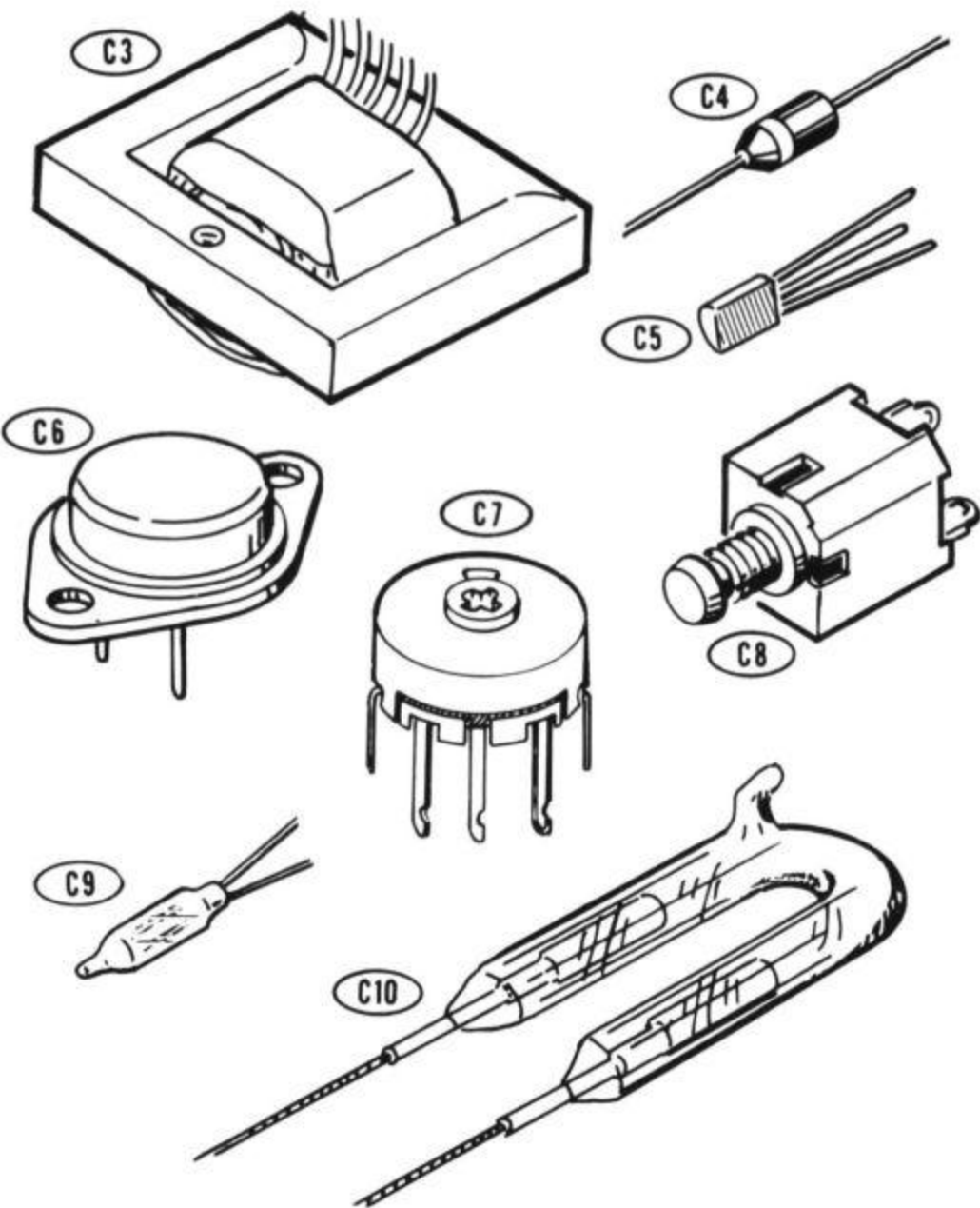

## PARTS LIST

Check each part against the following list. The key numbers correspond to the numbers in the Parts Pictorial (fold-out from Pages 4 and 5).

To order a replacement part, use the Parts Order Form furnished with this kit. If one is not available, see "Replacement Parts" inside the rear cover of the Manual.

KEY PART No.	PARTS No.	Per Kit	DESCRIPTION	PRICE Each
--------------	-----------	---------	-------------	------------

### RESISTORS

#### 1/2-Watt

A1	1-49	1	22 $\Omega$ (red-red-black)	.15
A2	2-143	1	133 k $\Omega$ precision	1.00
A2	2-14	1	1 M $\Omega$ precision	1.00

#### 2-Watt

A3	1-40-2	1	68 $\Omega$ (blue-gray-black)	.20
A3	1-10-2	1	47 k $\Omega$ (yellow-violet-orange)	.20
A3	1-24-2	1	100 k $\Omega$ (brown-black-yellow)	.20

### CAPACITORS

B1	21-16	1	.01 $\mu$ F disc	.15
B1	<del>21-31</del>	1	.02 $\mu$ F disc	.15
B2	27-61	1	.47 $\mu$ F Mylar*	.60
B3	23-112	1	2 $\mu$ F paper	3.25
B4	25-254	1	4 $\mu$ F electrolytic	.85

\*Dupont Registered Trademark

KEY PART No.	PARTS No.	Per Kit	DESCRIPTION	PRICE Each
--------------	-----------	---------	-------------	------------

### ELECTRICAL PARTS

C1	40-336	1	Pickup coil	1.50
C2	40-368	1	Trigger transformer	4.05
C3	54-287	1	Power transformer	4.40
C4	57-27	2	1N2071 silicon diode	.75
C5	57-51	1	Silicon controlled rectifier (SCR) TIC-47	3.85
C6	417-278	1	PNP germanium power transistor (selected)	2.40
C7	11-90	1	200 $\Omega$ control	1.15
C8	64-84	1	Pushbutton switch	1.60
C9	412-34	1	Neon lamp	1.50
C10	412-73	1	Strobe tube	5.25

### HARDWARE

#### #3 Hardware

D1	250-49	1	3-48 x 1/4" screw	.05
D2	250-133	1	3-48 x 7/16" brass screw	.05
D3	252-1	2	3-48 nut	.05
D4	254-7	1	#3 lockwasher	.05
D5	255-29	1	#3 spacer	.05



KEY PART No. No.	PARTS Per Kit	DESCRIPTION	PRICE Each
<b>#4 Hardware</b>			
D6 250-186	7	4-24 x 3/8" self-tapping screw	.05
<b>#6 Hardware</b>			
D7 250-559	7	6-20 x 5/8" self-tapping screw	.05
D8 250-89	2	6-32 x 3/8" screw	.05
D9 252-3	2	6-32 nut	.05
D10 254-1	2	#6 lockwasher	.05
<b>Control Hardware</b>			
D11 254-5	1	Control lockwasher	.05
D12 253-10	1	Control flat washer	.05
D13 252-7	1	Control nut	.05
<b>WIRE</b>			
89-4	1	Power cord	1.00
344-52	1	Red hookup wire	.05/ft
343-2	1	Shielded cable	.15/ft
<b>MISCELLANEOUS</b>			
E1 73-64	2	Foam tape	.40
E2 73-3	1	Grommet	.15
E3 73-141	1	Double-sided tape	.15
214-183	1	Housing	2.55
<i>Consisting of:</i>			
E3	1	Housing half (component)	
E4	1	Housing half (cover)	

KEY PART No. No.	PARTS Per Kit	DESCRIPTION	PRICE Each
<b>Miscellaneous (cont'd.)</b>			
E5 260-58	1	Battery cable clip (black insulation)	.45
E5 260-59	1	Battery cable clip (red insulation)	.45
E6 413-30	1	Lens	.40
E7 95-7	1	Pickup shell	.70
E8 95-8	1	Pickup cover	.70
E9 207-34	1	Pickup trigger housing	.70
E10 258-42	1	Hairpin spring	.05
E11 258-84	2	Metal strip	.05
E12 431-57	1	Terminal strip	.15
E13 475-5	1	RF core	1.65
	1	85-1191-1 Circuit board	1.80
	1	390-388 Kit name label	.25
	1	390-975 Kit model label	.30
	1	391-34 Blue and white label	
		Parts Order Form	
		Kit Builders Guide	
		Manual (See front cover for part number.)	2.00
		Solder (Additional 3' rolls of solder, #331-6, can be ordered for 25 cents each.)	

The prices apply only on purchases from the Heath Company where shipment is to a U.S.A. destination. Add 10% (minimum 25 cents) to the price when ordering from a Heathkit Electronic Center to cover local sales tax, postage, and handling. Outside the U.S.A. parts and service are available from your local Heathkit source and will reflect additional transportation, taxes, duties, and rates of exchange.



# PARTS PICTORIAL (Continued)

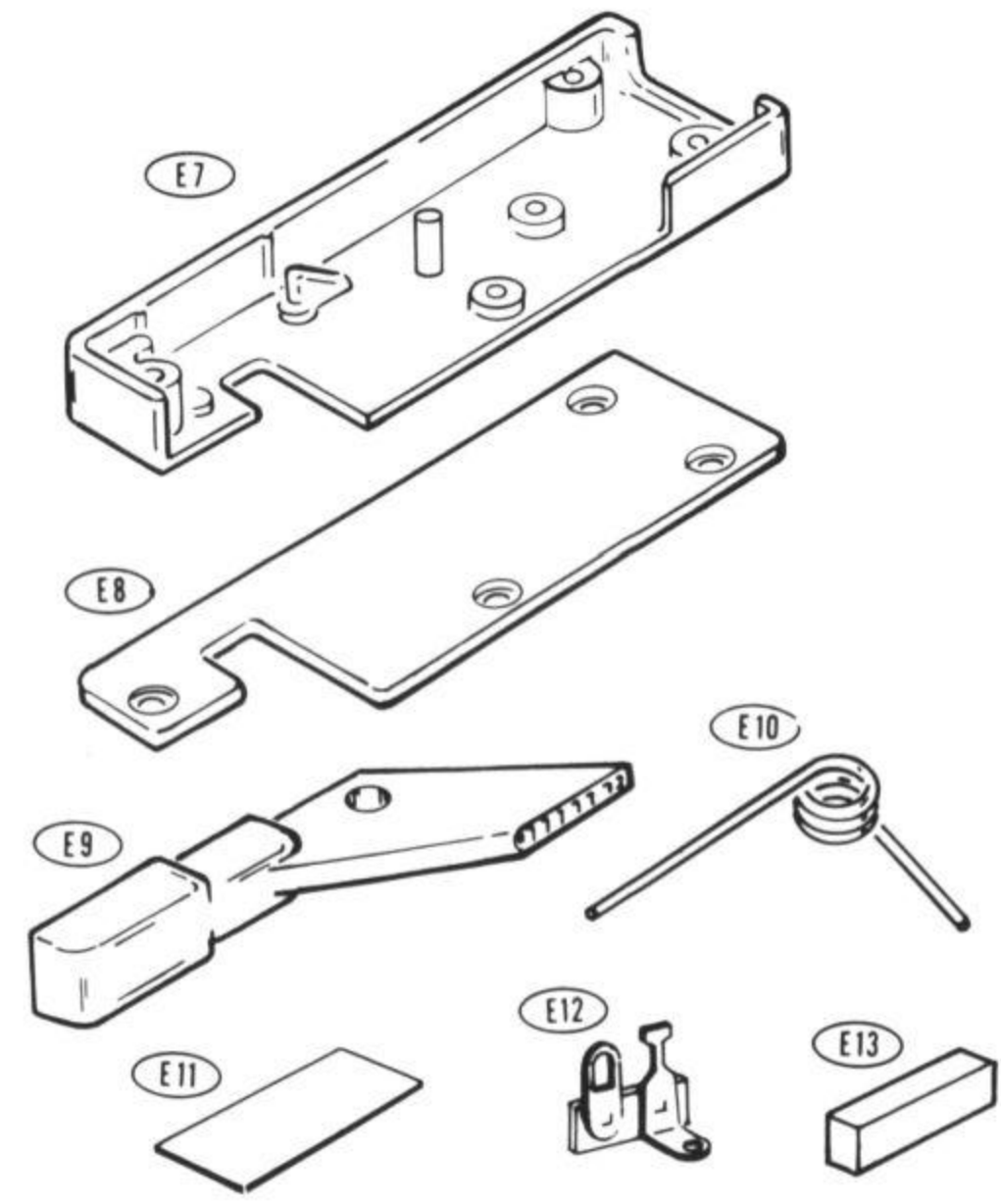
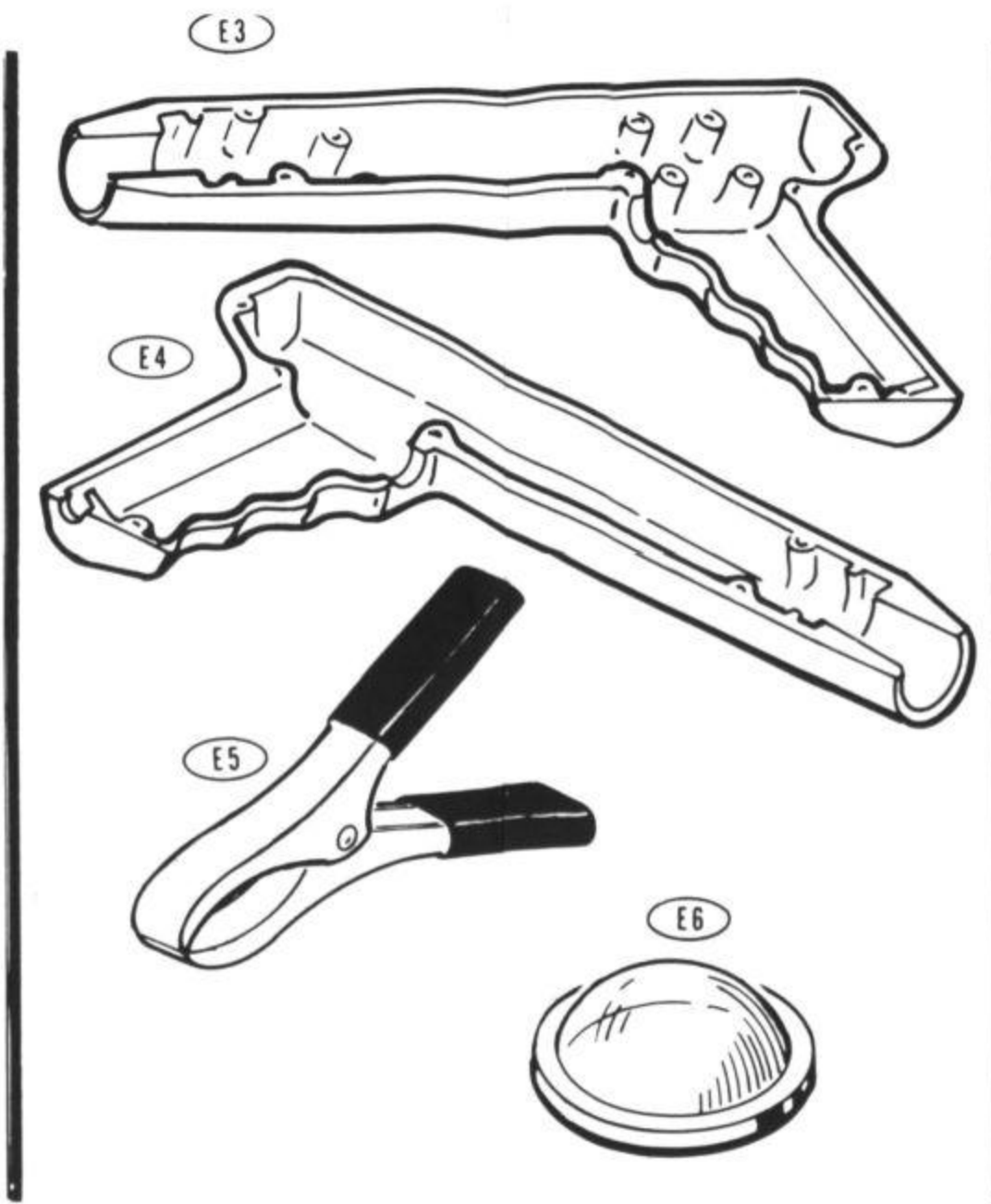
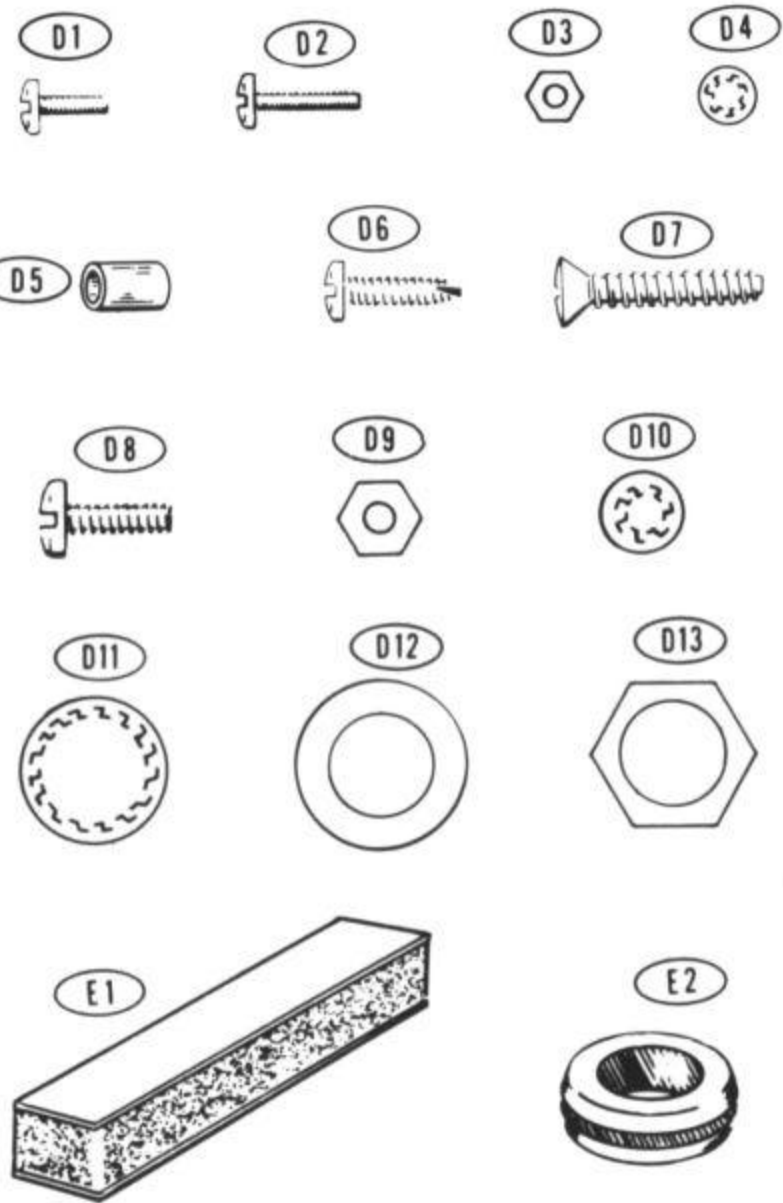

# START

FOR GOOD SOLDERED CONNECTIONS, YOU MUST KEEP THE SOLDERING IRON TIP CLEAN...  
WIPE IT OFTEN WITH A DAMP SPONGE OR CLOTH.



NOTE: When installing disc capacitors, remove any excess coating from the leads. Use long-nose pliers to remove this coating.

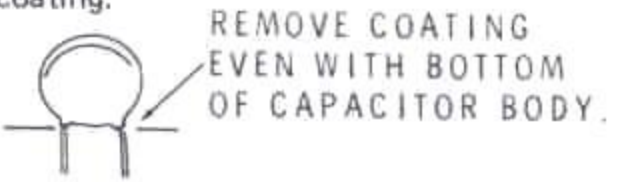

( ) .01  $\mu$ F disc.

( ) .01  $\mu$ F disc.

( ) .47  $\mu$ F Mylar.

( ) 4  $\mu$ F electrolytic. Position the capacitor as shown with the positive lead in the positive (+) marked hole.



( ) Solder all leads to the foil and cut off the excess lead lengths.



# CONTINUE

- ( ) 133 k $\Omega$  precision.
- ( ) 1 M $\Omega$  precision.
- ( ) 100 k $\Omega$ , 2-watt (brown-black-yellow).
- ( ) 47 k $\Omega$ , 2-watt (yellow-violet-orange).
- ( ) 22  $\Omega$  (red-red-black).
- ( ) 68  $\Omega$ , 2-watt (blue-gray-black).
- ( ) Solder all leads to the foil and cut off the excess lead lengths.

### PICTORIAL 1



# START



( ) Silicon controlled rectifier (#57-51).

NOTE: When installing the silicon controlled rectifier, place the A, G, and K leads of the rectifier in the corresponding A, G, and K holes in the circuit board. Position the silicon controlled rectifier 1/4" above the circuit board. Solder the leads to the foil and cut off the excess lead lengths.

NOTE: DIODES MAY BE SUPPLIED IN ANY OF THE FOLLOWING SHAPES. THE CATHODE END OF THE DIODE IS MARKED WITH A BAND OR BANDS. ALWAYS POSITION THIS END AS SHOWN IN THE PICTORIAL.

BAND OR BANDS

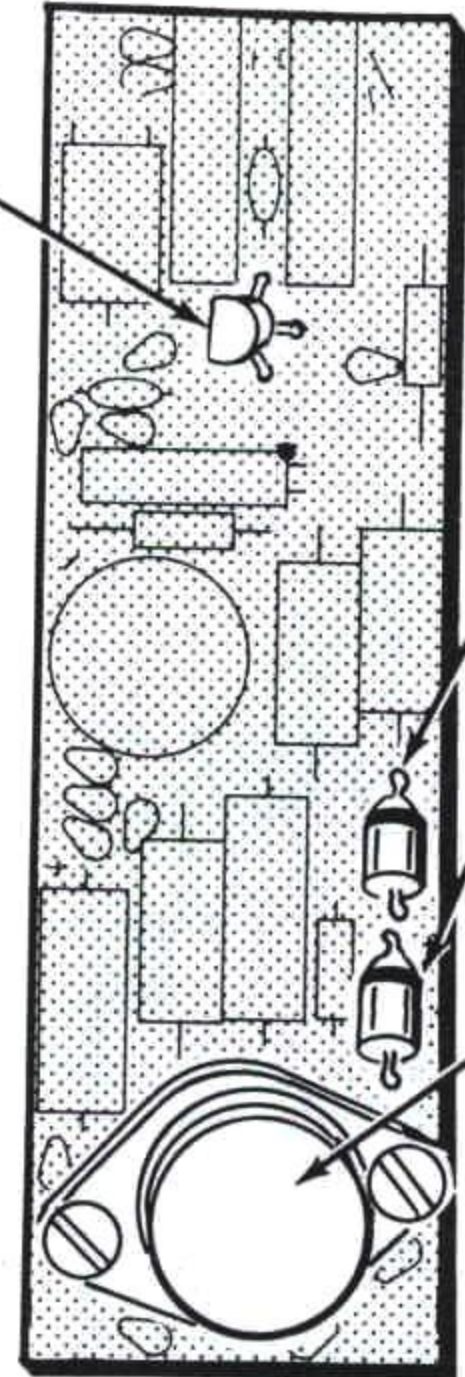

PICTORIAL 2

# CONTINUE



( ) 1N2071 silicon diode (#57-27).

( ) 1N2071 silicon diode (#57-27).

( ) PNP transistor (#417-278).

Note that the two leads are closer to one end than to the other of the transistor body. Position the transistor so its leads match the holes marked B and E on the circuit board and so that it fits within the outline on the circuit board. Then install the transistor on the circuit board, using two 6-32 x 3/8" screws, two #6 lockwashers, and two 6-32 nuts.

( ) Solder all leads to the foil and cut off the excess lead lengths.



**START** ↓

( ) Trigger transformer (#40-368). Place the green, red, and black transformer leads into the corresponding GRN, RED, and BLK holes in the circuit board. Do not cut or remove additional insulation from these leads. Solder the leads to the foil and cut off the excess lead lengths. Then position the transformer against the circuit board.

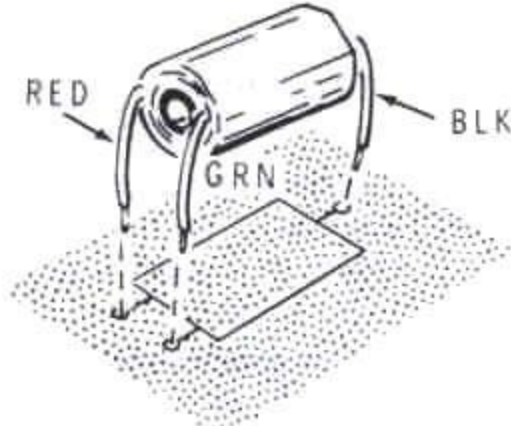

( ) Neon lamp (#412-34). Position the neon lamp with the red mark as shown and bend the leads down. Then install the lamp with its red mark next to the black dot on the circuit board. Solder the leads to the foil and cut off the excess lead lengths.

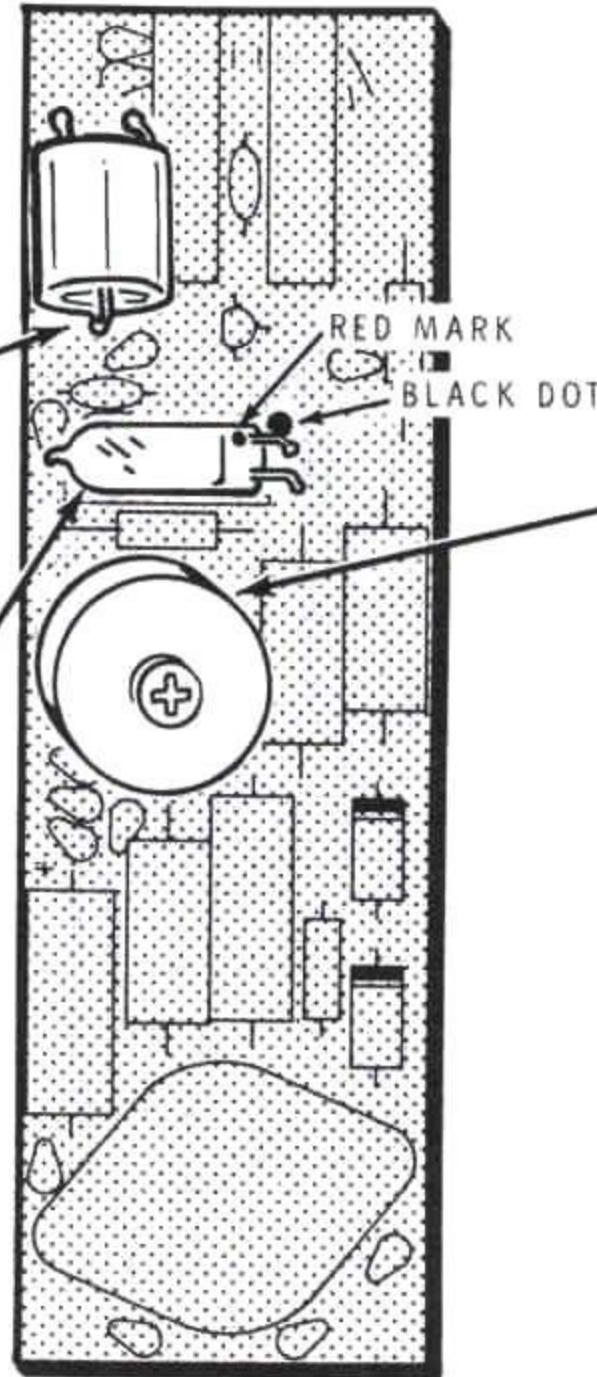
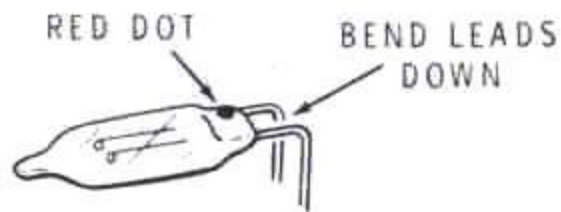

PICTORIAL 3

**CONTINUE**



( ) 200 Ω control. Solder the control lugs to the foil and cut off the excess lead lengths.





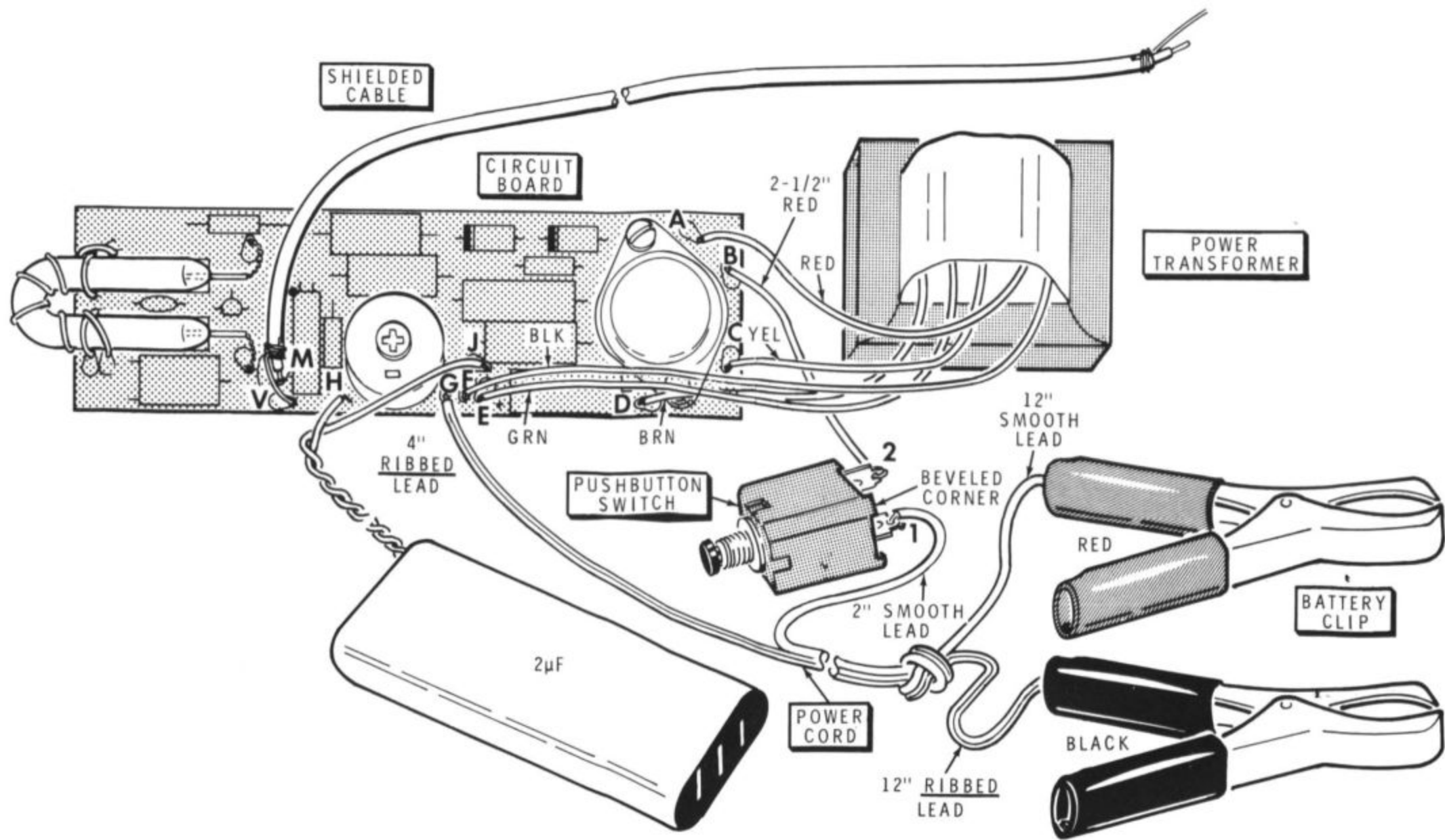

**PICTORIAL 5**

START

NOTE: Be careful in handling the strobe tube to prevent damage to the glass seal or the tube.

- ( ) Bend the strobe tube leads into a half-circle as shown.

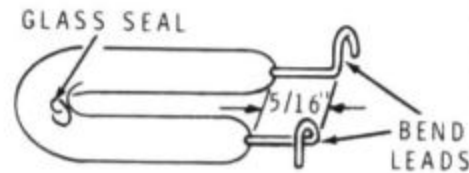

- ( ) With the glass seal facing up, position the end of the strobe tube  $1/2$ " from the edge of the circuit board. Then install the leads at K and L and solder them to the foil. Cut off the excess lead lengths.

NOTE: When bare wire is called for in the following steps, use the red hookup wire and cut it to the specified lengths; then remove all of the insulation.

The steps performed in this Pictorial are in this area of the circuit board.

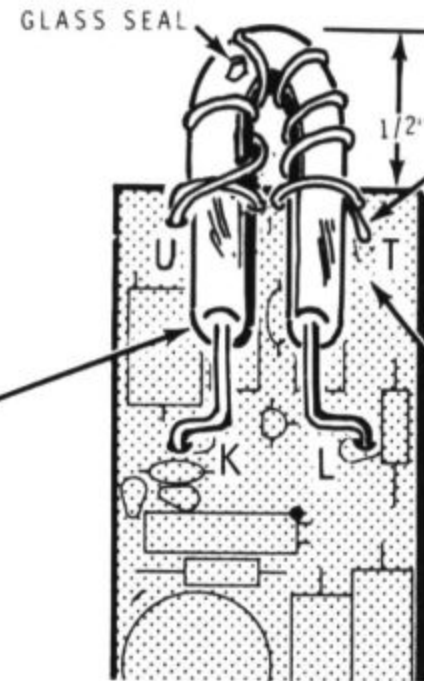

PICTORIAL 4

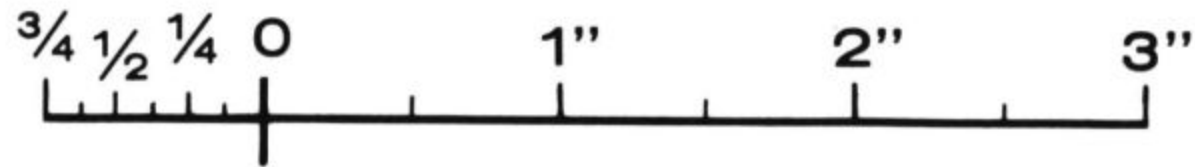

PART NUMBER

CONTINUE

- ( ) Bend a 2" bare wire into a "U" shape. Install the wire in holes N and P over the strobe tube, and draw the wire snugly against the tube. Solder the wire ends to the foil and cut off the excess lengths.

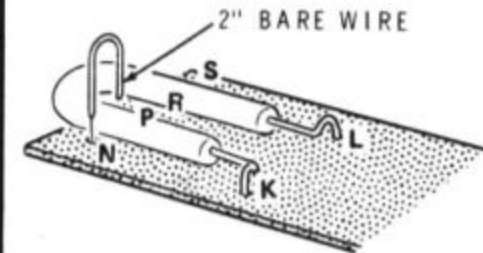

- ( ) Bend another 2" bare wire into a "U" shape and repeat the previous step at holes R and S.

- ( ) Insert one end of a 6" bare wire  $1/4$ " into hole U. Solder this wire to the foil. Wrap the free end of this wire around the strobe tube five complete turns. Then insert the free end of this wire into hole T and solder it to the foil.

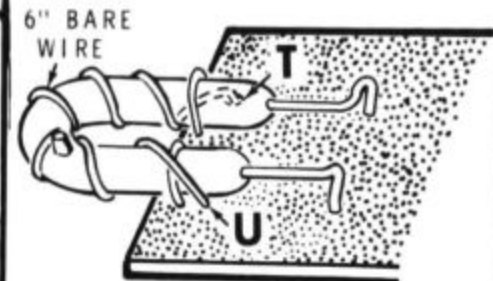



## WIRING

Refer to Pictorial 5 (fold-out from Page 10) for the following steps.

- ( ) Twist the leads of the 2  $\mu$ F capacitor as shown.
- ( ) Connect either capacitor lead to circuit board hole J (S-1).
- ( ) Connect the other capacitor lead to circuit board hold H (S-1).

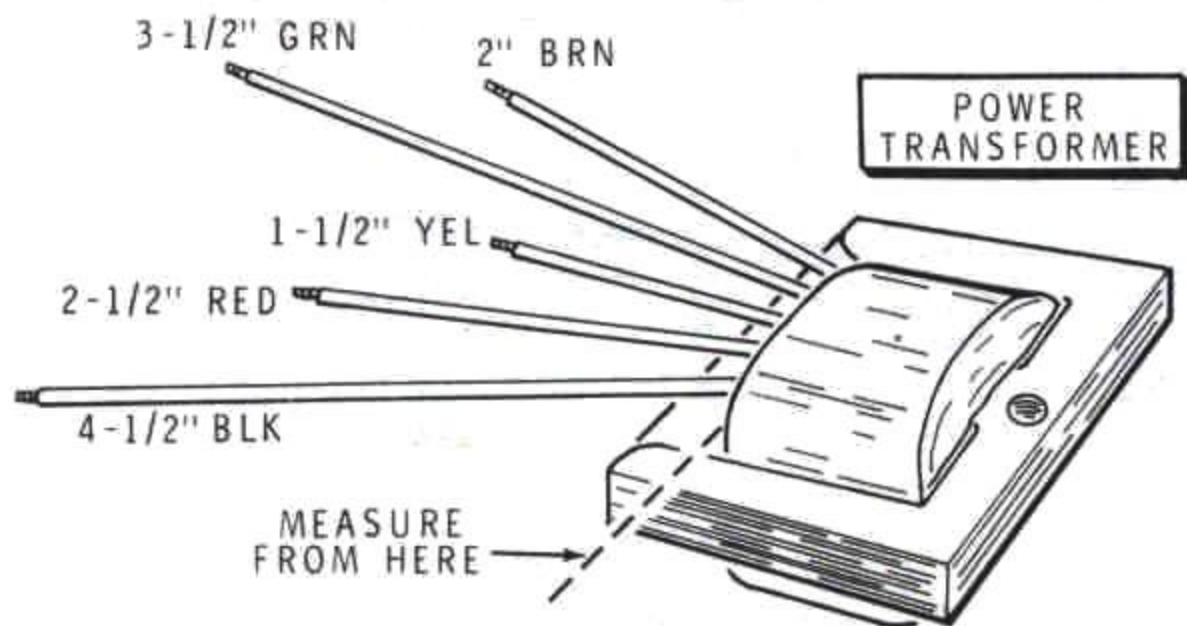

Detail 5A

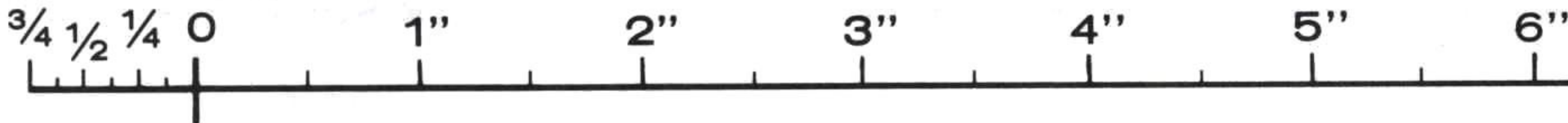

- ( ) Refer to Detail 5A and cut the power transformer leads to the indicated lengths. Measure the leads from where they come out of the transformer. Remove 1/4" of insulation from the end of each lead. Twist together the small strands of wire at the end of each lead; then melt a small amount of solder on each of the exposed ends.

Connect the transformer leads to the circuit board as follows:

- ( ) Black lead to hole F (S-1).
- ( ) Green lead to hole E (S-1).
- ( ) Brown lead to hole D (S-1).
- ( ) Yellow lead to hole C (S-1).
- ( ) Red lead to hole A (S-1).
- ( ) Cut a 2-1/2" length of red hookup wire and remove 1/4" of insulation from each end.
- ( ) Connect one end of this wire to circuit board hole B (S-1).
- ( ) Refer to Pictorial 5 and place the pushbutton switch near the circuit board. Position the beveled corner of the switch as shown. Connect the free end of the red wire to lug 2 of the switch (S-1).

- ( ) Refer to Detail 5B and prepare both ends of the power cord. Note that one power cord lead is identified with ribs, while the other lead is smooth.
- ( ) At the short end of the prepared power cord, connect the smooth 2" lead to lug 1 of the pushbutton switch (S-1).
- ( ) Connect the ribbed 4" lead to circuit board hole G (S-1). Then cut off the excess lead length.

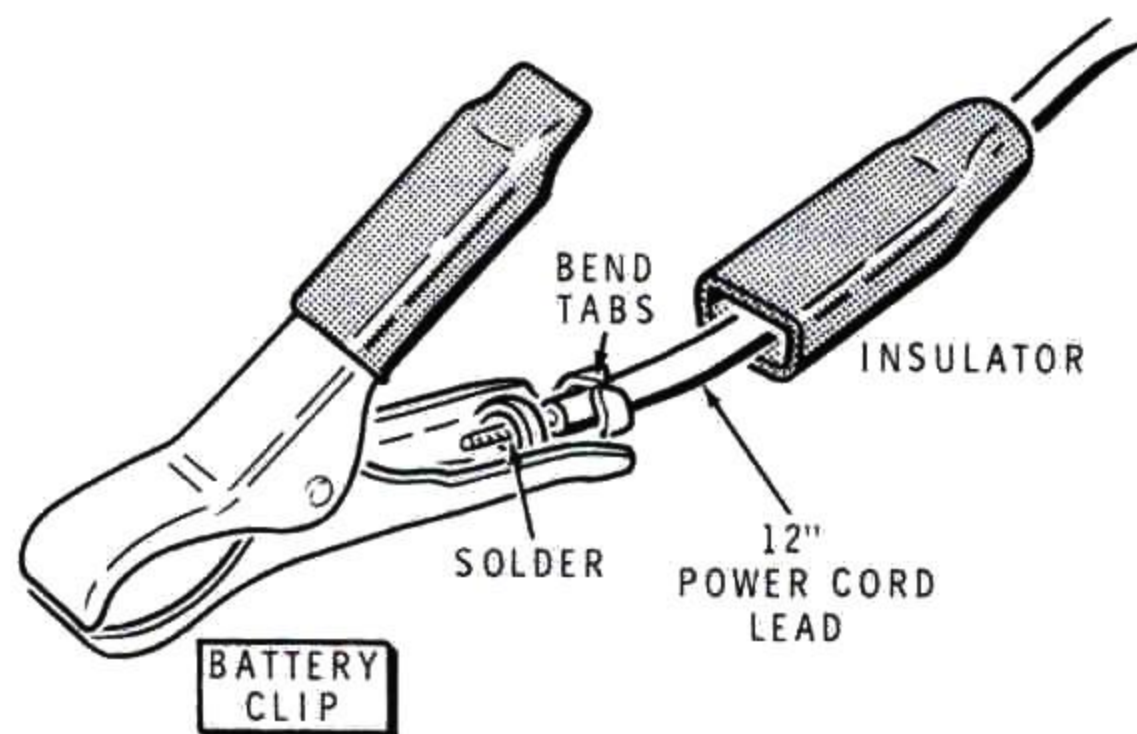

Detail 5C

- ( ) Refer to Detail 5C and locate the battery clip with the black insulators. Slide the insulator off one of the handles and onto the ribbed 12" power cord lead. Solder the lead to the solder lug of the handle and, after it has cooled, bend the tabs over the power cord insulation. Then slide the insulator onto the handle.

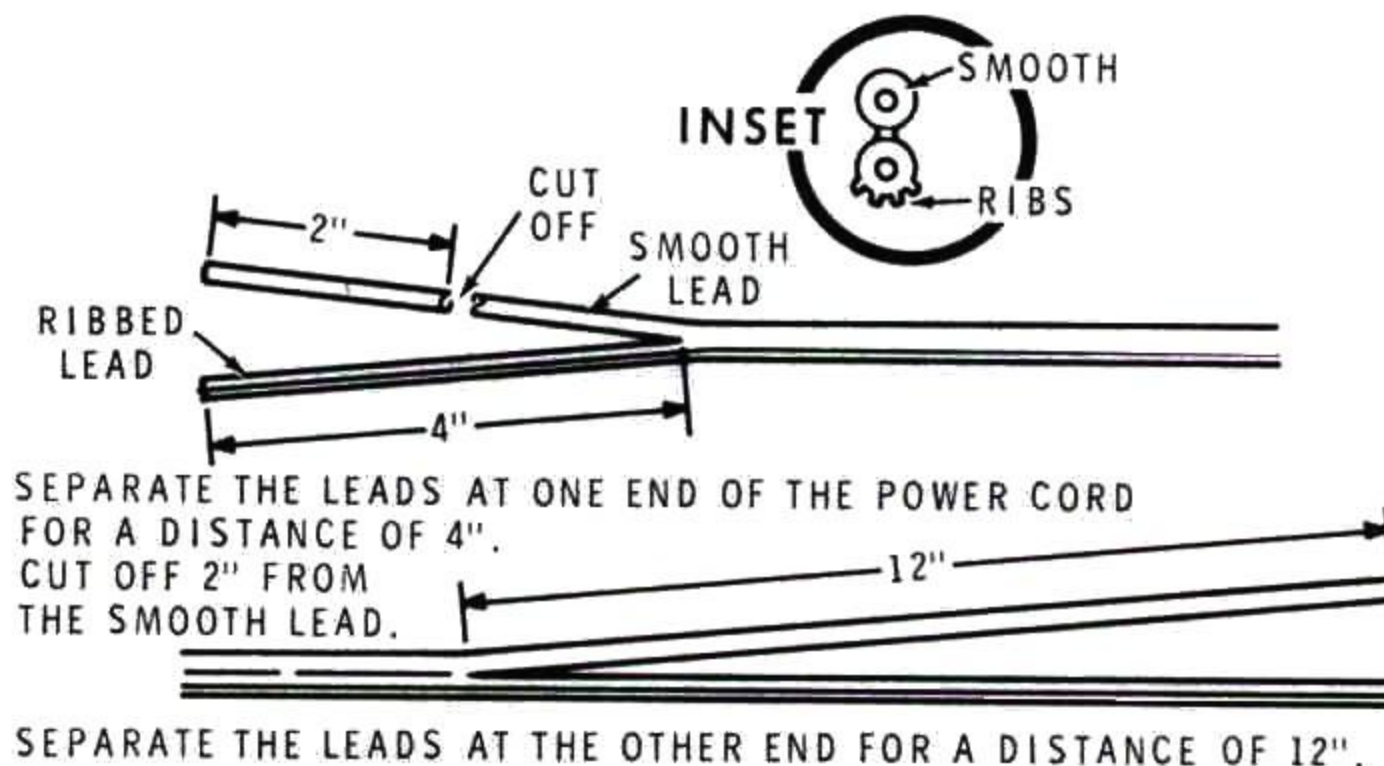

SEPARATE THE LEADS AT ONE END OF THE POWER CORD FOR A DISTANCE OF 4".  
CUT OFF 2" FROM THE SMOOTH LEAD.

SEPARATE THE LEADS AT THE OTHER END FOR A DISTANCE OF 12".



TIE A KNOT IN THE 12" END OF THE CORD AT THE POINT WHERE THE LEADS SEPARATE.

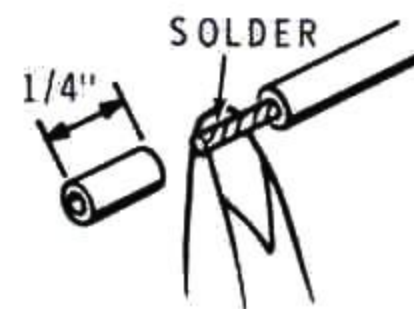

REMOVE 1/4" OF INSULATION FROM THE END OF EACH LEAD. TWIST THE SMALL STRANDS TOGETHER; THEN MELT A SMALL AMOUNT OF SOLDER ON THE EXPOSED WIRE ENDS.

Detail 5B



CUT THE CABLE ACCORDING TO THE DIMENSIONS BELOW. PREPARE EACH END AS SHOWN.

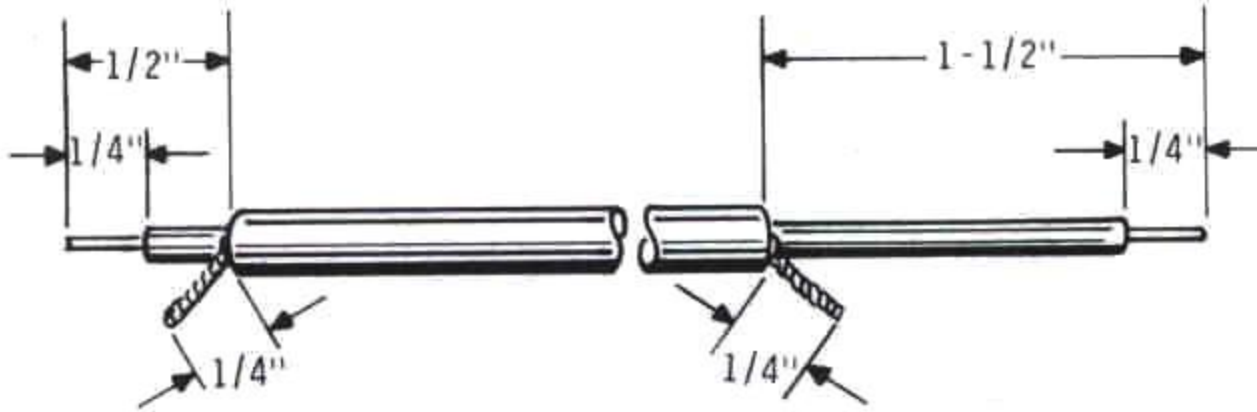

① TAKING CARE NOT TO CUT THE OUTER SHIELD OF VERY THIN WIRES, REMOVE THE OUTER INSULATION.



② UNBRAID THE SHIELD WITH A NAIL OR POINTED TOOL AND TWIST THE SHIELD WIRES INTO ONE STRAND. REMOVE 1/4" OF INSULATION FROM EACH OF THE INNER LEADS. APPLY A SMALL AMOUNT OF SOLDER TO THE END OF THE INNER LEAD. USE ONLY ENOUGH HEAT FOR THE SOLDER TO FLOW.

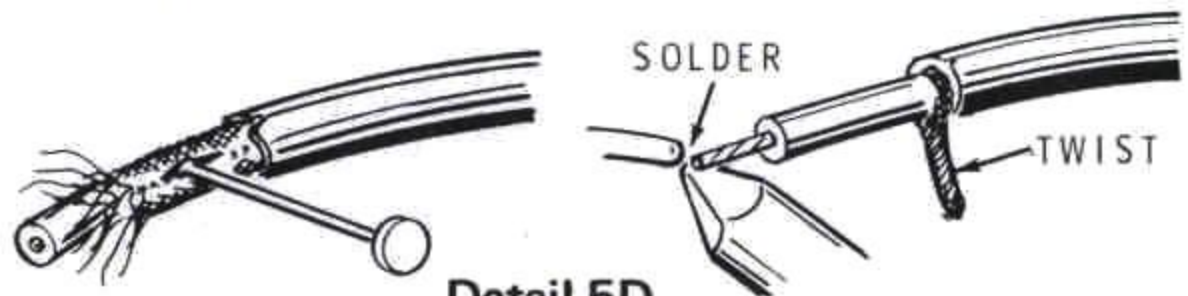

Detail 5D

- ( ) Likewise, install the battery clip with the red insulators on the smooth power cord lead.
  - ( ) Refer to Detail 5D and prepare both ends of the shielded cable as shown.
  - ( ) Refer to Detail 5E and prepare the shield lead at both ends of this cable as shown.
- Connect the 1/2" end of the prepared shielded cable to the circuit board as follows:
- ( ) Inner lead to hole M (S-1). Cut off the excess lead length.
  - ( ) Shield lead to hole V (S-1). Cut off the excess lead length.
  - ( ) Carefully examine the circuit board foil to make sure all leads are soldered to the foil. Then cut off the excess lead lengths.

① BEND THE SHIELD BACK AND AGAINST THE OUTER INSULATION.

② WRAP A 2-1/2" BARE WIRE AROUND THE OUTER INSULATION AND SHIELD. THEN SOLDER THE BARE WIRE TO THE SHIELD.



Detail 5E

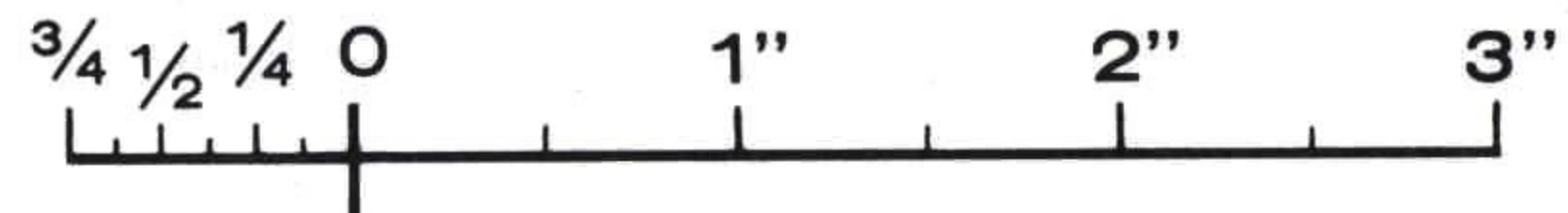



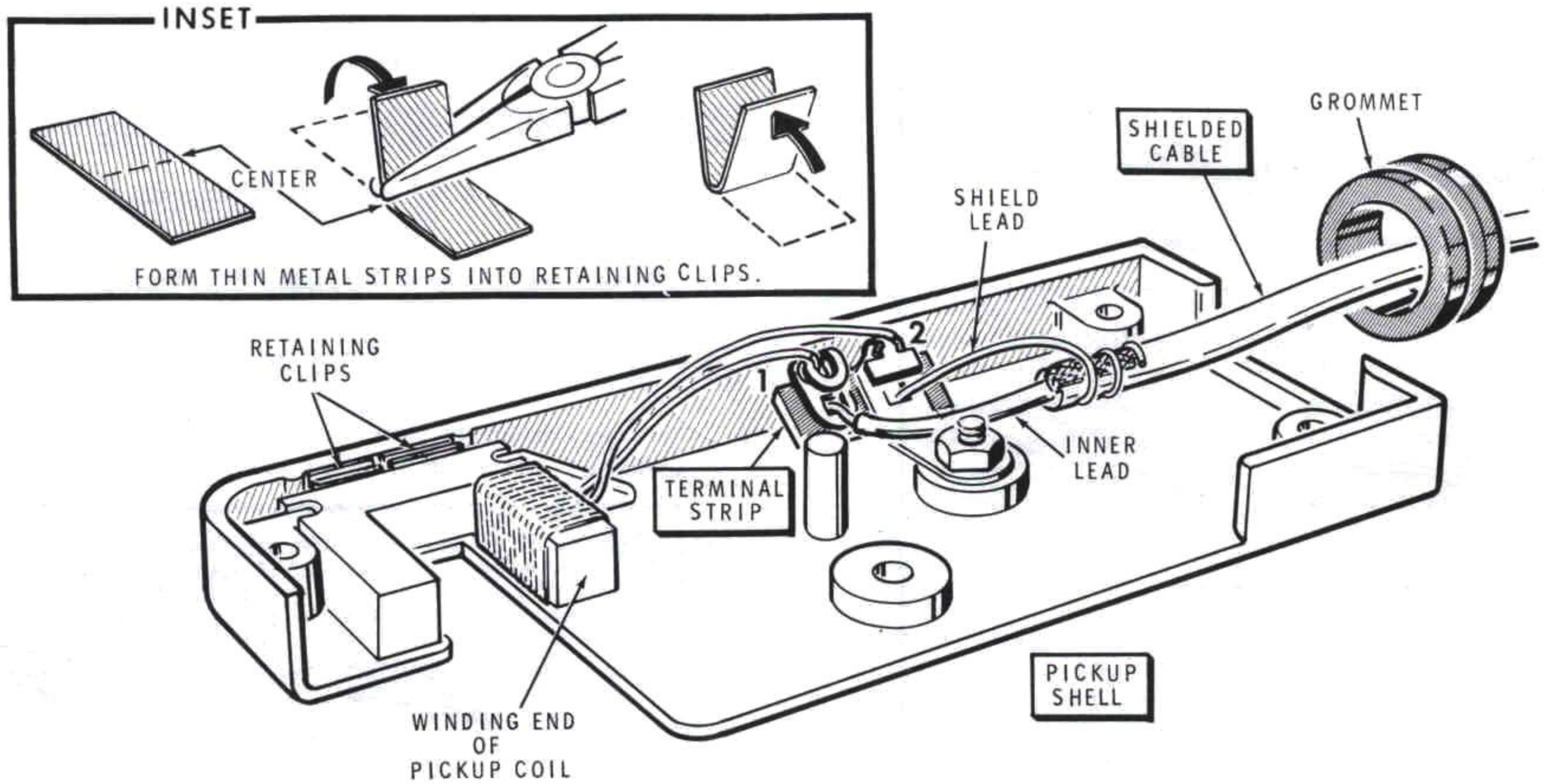

PICTORIAL 6



Refer to Pictorial 6 for the following steps.

- ( ) Refer to Detail 6A and install the terminal strip in the pickup shell. Use a 3-48 x 1/4" screw, a #3 lockwasher, and a 3-48 nut.
- ( ) Place a grommet on the free end of the shielded cable. Push the grommet back from the end of the cable and out of the way.

NOTE: When you solder to the terminal strip in the following steps, apply the solder to the back of the terminal strip. Cut off the excess lead length after each lead is soldered to its eyelet.

Connect the free end of the shielded cable to the terminal strip as follows:

- ( ) Shield lead to the eyelet in lug 2 (S-1).
- ( ) Inner lead to the eyelet in lug 1 (S-1).
- ( ) Carefully bend the terminal strip backward and down into the pickup shell as far as it will go. Then bend the lugs of the terminal strip as shown. NOTE: The lugs of the terminal strip must not protrude above the sides of the pickup shell.
- ( ) Install the pickup coil in the pickup shell with the winding end of the coil positioned as shown.
- ( ) Refer to the inset drawing of Pictorial 6 and form the metal strips into "retaining clips" as shown. Be sure to bend the metal strips exactly in the center.
- ( ) Insert both of these "retaining clips" between the pickup coil and the pickup shell. Push them down as far as they will go.
- ( ) Connect either lead of the pickup coil to lug 1 of the terminal strip (S-1).

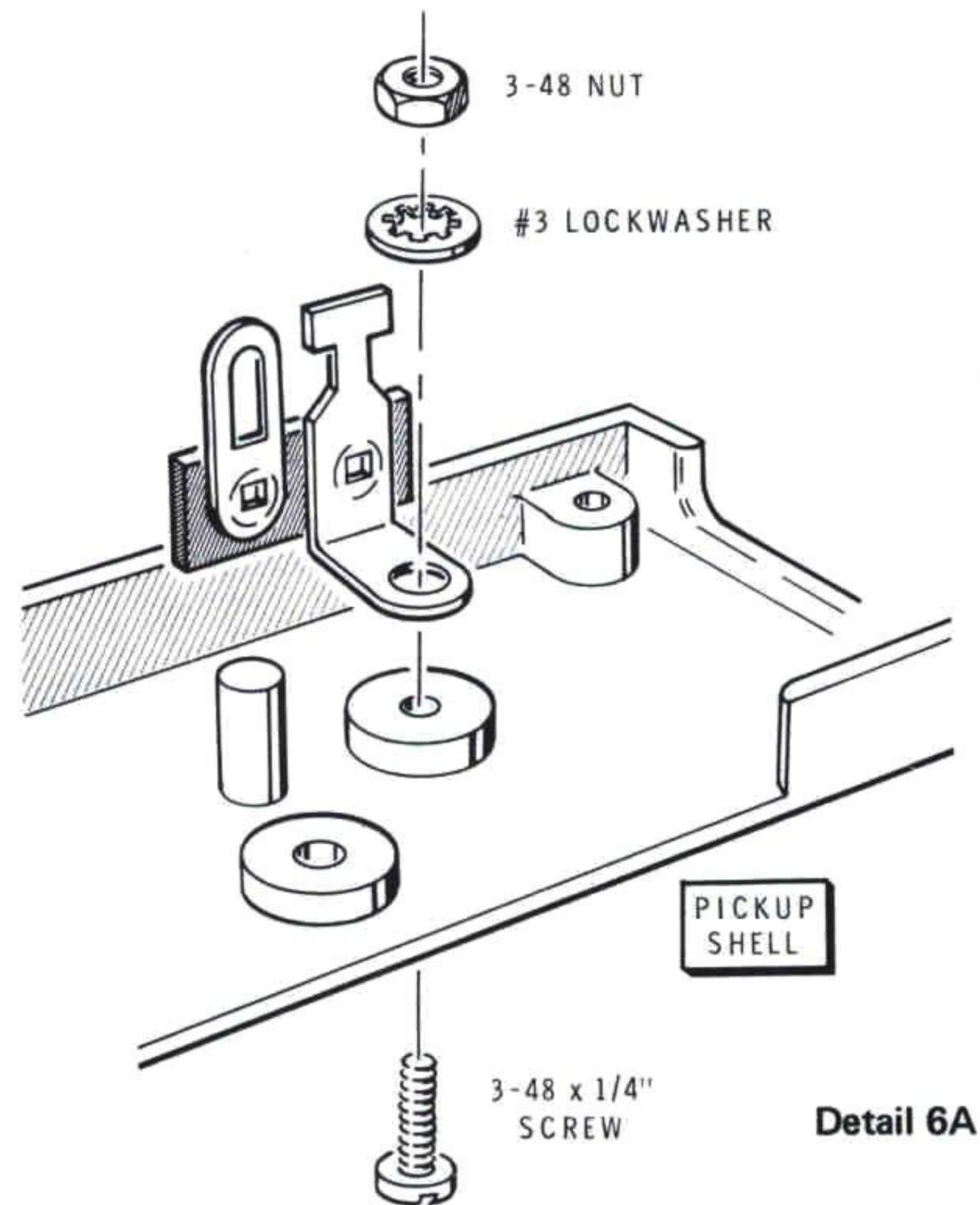

- ( ) Connect the other lead of the pickup coil to lug 2 of the terminal strip (S-1).

This completes the wiring of the Timing Light. Check it to be sure all connections are soldered and that all excess lead lengths have been cut off.



Refer to Pictorial 7 for the following steps.

- ( ) Refer to Detail 7A (fold-out from Page 17) and remove the protective paper backing from both sides of the double-sided tape. First place the tape on the RF core; then install the RF core in the pickup trigger housing as shown.
- ( ) Place the grommet into the cutout in the end of the pickup shell.
- ( ) Place the hairpin spring on the plastic post. Position the spring with the longer arm as shown.
- ( ) Partially compress the spring. Then place the longer arm of the spring into the slot in the pickup trigger.
- ( ) Press the trigger to further compress the spring and position the hole in the pickup trigger over the hole in the pickup shell.
- ( ) Insert a 3-48 x 7/16" brass screw up through the hole in the pickup shell and through the hole in the pickup trigger. Then place a #3 spacer on the brass screw and into the hole in the pickup trigger.
- ( ) place the pickup cover over the pickup shell. Press down firmly on the end of the cover over the grommet.
- ( ) Secure the cover with 4-24 x 3/8" self-tapping screws. Tighten these screws a little at a time to prevent breaking the cover.
- ( ) Install a 3-48 nut on the brass screw.

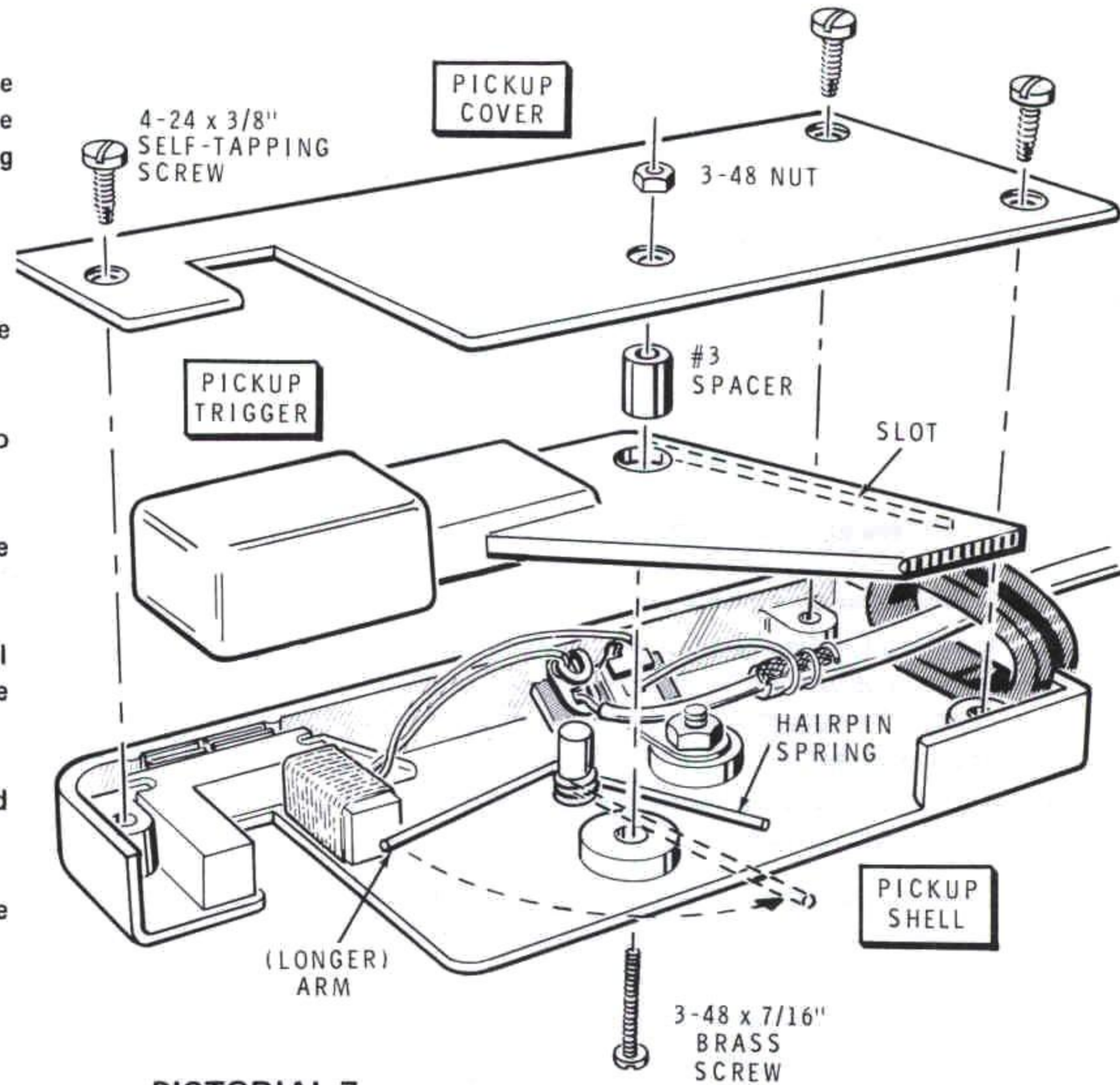

PICTORIAL 7



## COMPONENT HOUSING ASSEMBLY

Refer to Pictorial 8 (fold-out from this page) for the following steps.

- ( ) Position the component half of the housing as shown.
- ( ) Position the twisted capacitor leads under the circuit board, and place the circuit board and power transformer in the component housing as shown.
- ( ) Install a 4-24 x 3/8" self-tapping screw at each corner of the circuit board. Carefully tighten each of these screws a little at a time to secure the circuit board to the housing. Do not overtighten these screws.
- ( ) Mount the power transformer to the housing using 6-20 x 5/8" self-tapping screws.
- ( ) Refer to Detail 8A and install the pushbutton switch in the component housing with a control lockwasher, a control flat washer, and a control nut. Position them so the nut and flat washer are on the outside of the housing and the lockwasher is on the inside of the housing.
- ( ) Cut one length of foam tape in half.
- ( ) Position the 2  $\mu$ F capacitor so the twisted leads are on the right side of the capacitor as shown in the inset drawing.
- ( ) Peel the paper backing from one side of a prepared length of foam tape. Press this length of tape onto one end of the 2  $\mu$ F capacitor as shown.
- ( ) Likewise, press the other prepared length of foam tape onto the other end of the capacitor.

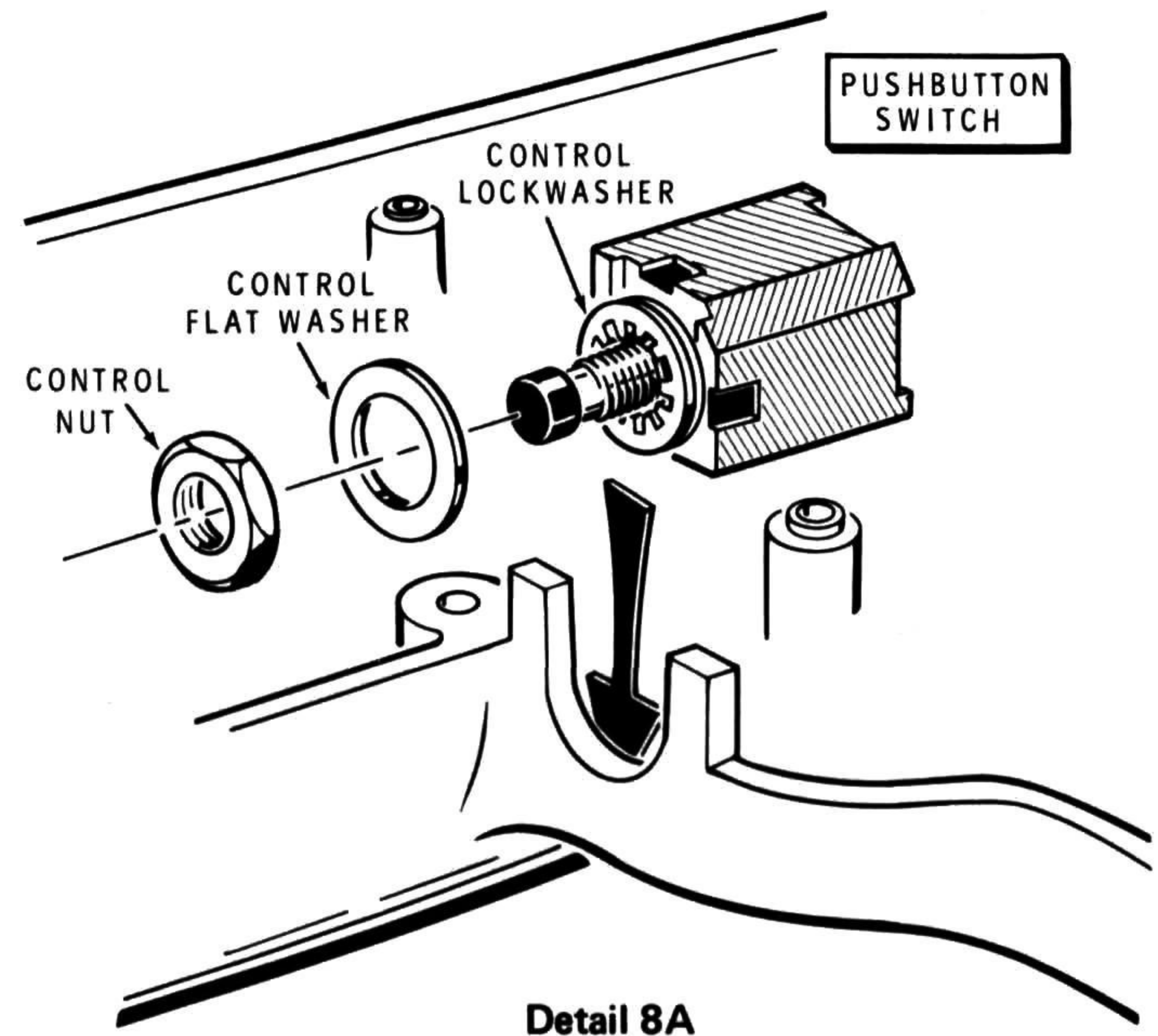

- ( ) Peel the backing paper from the upper side of both lengths of foam tape. Then turn the capacitor over and press it into the housing handle. Be sure the upper edge of the capacitor is positioned away from the pushbutton switch.

This completes the assembly of the component housing. Proceed to "Adjustments."



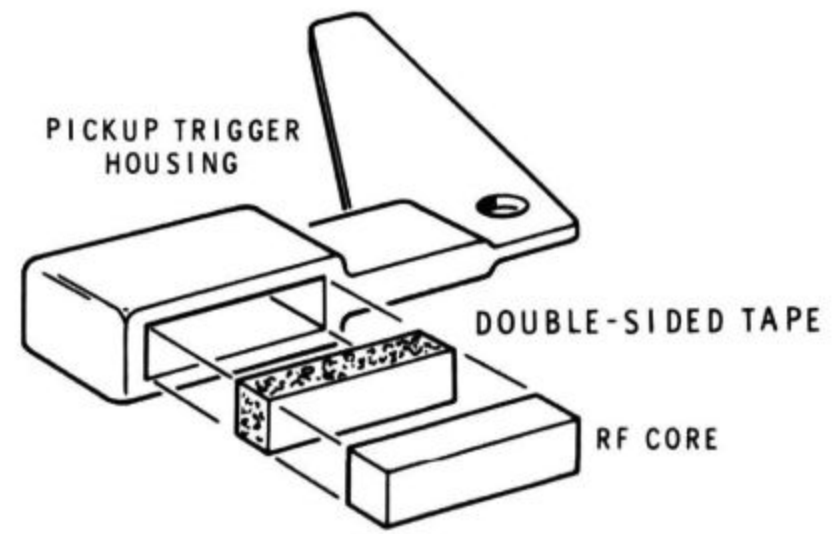
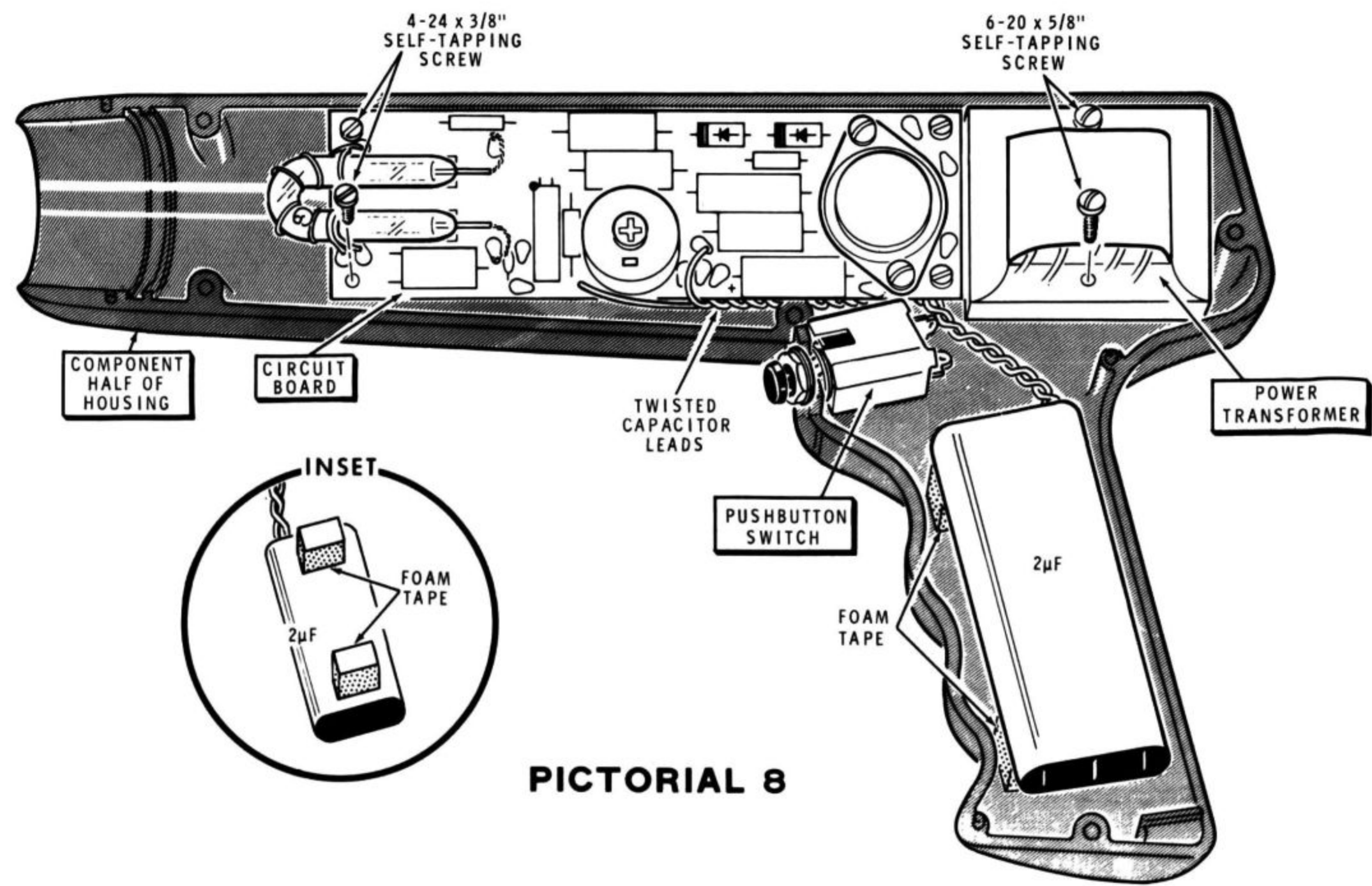

**Detail 7A**



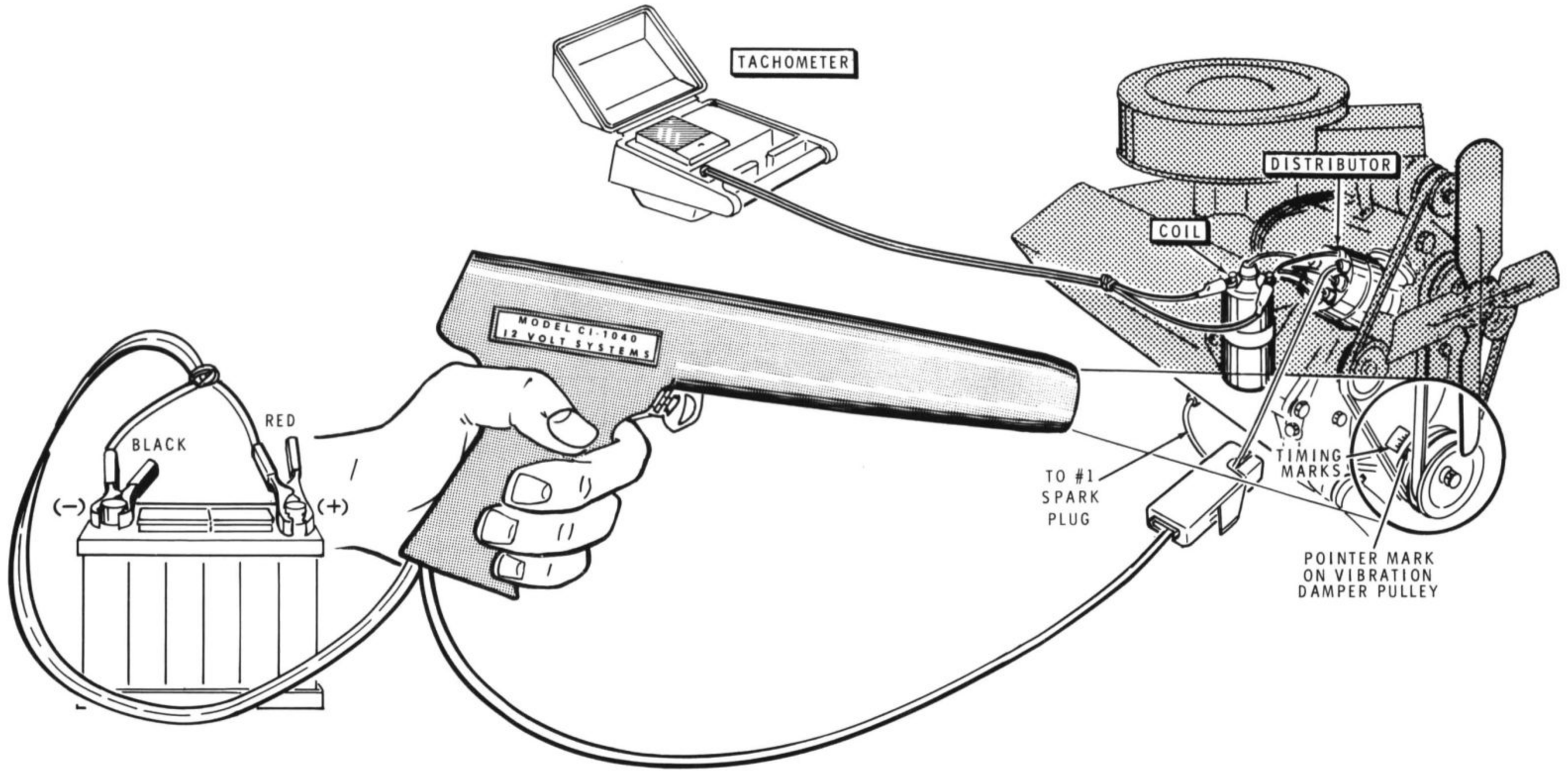

**Figure 3**

## ADJUSTMENTS

Use one of the two procedures below to adjust the Automotive Timing Light. Reliable operation will be obtained if you use the steps entitled "Adjustments Using the Neon Lamp." A slight increase in strobe tube intensity may be obtained if you use a DC voltmeter and the steps under "Adjustments Using a DC Voltmeter."

### **DANGER!**

### **SHOCK HAZARD**

Avoid contact with the two leads of the strobe tube when the battery clips are connected to the battery.

NOTE: If you do not obtain the proper response in the following adjustments, refer to the "In Case of Difficulty" section on Page 26 to locate and correct the trouble. After you locate the trouble and correct it, return to this section of the Manual and complete the adjustments.

### ADJUSTMENTS USING THE NEON LAMP

Refer to Figure 1 for the following steps.

- ( ) Temporarily secure the trigger pickup cable and the power cord to the handle with a rubber band or masking tape. This will prevent the shielded cable and the power cord from breaking where they connect to the circuit board.

- ( ) Using a small screwdriver, turn the 200  $\Omega$  control fully clockwise.

NOTE: In the following steps, you can use a separate 15 volt DC power supply (of at least 1.5 ampere capacity), or the battery of your automobile with the engine running.

- ( ) Connect the black battery clip to the negative (–) terminal of your power supply or to the negative terminal of the battery in your automobile.
- ( ) Connect the red battery clip to the positive (+) terminal of the power supply or to the positive terminal of the battery.
- ( ) Hold the pushbutton switch pressed in (a faint squealing sound is normal) and slowly rotate the 200  $\Omega$  control counterclockwise until the small neon lamp just begins to glow.
- ( ) Release the pushbutton switch and disconnect the battery clips.
- ( ) Remove the rubber band or masking tape holding the trigger pickup cable and the power cord to the handle.

This completes "Adjustments Using the Neon Lamp." Proceed to "Final Assembly."



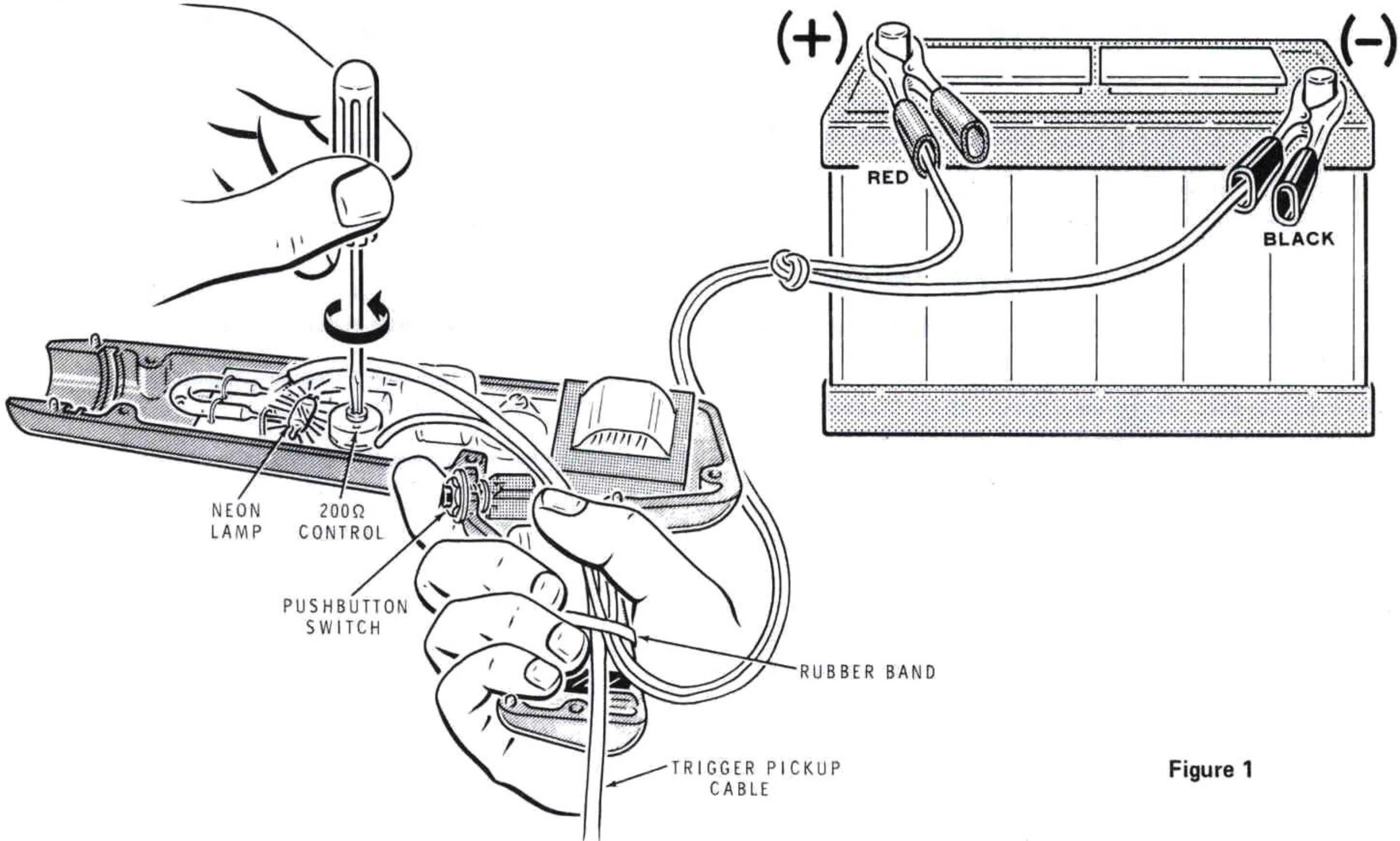

Figure 1

## ADJUSTMENTS USING A DC VOLTMETER

Refer to Figure 2 for the following steps.

- ( ) Temporarily secure the triggering pickup cable and the power cord to the handle with a rubber band or masking tape while performing the following adjustments. This will prevent the shielded cable and power cord from breaking where they connect to the circuit board.
- ( ) Using a small screwdriver, turn the 200  $\Omega$  control fully clockwise.
- ( ) Connect the negative (-) voltmeter lead to the strobe tube lead at point K, and connect the positive (+) voltmeter lead to point L.

NOTE: In the following steps, you can use a separate 15 volt DC power supply (of at least 1.5 ampere capacity), or the battery of your automobile (with the engine running).

- ( ) Connect the black battery clip to the negative (-) terminal of your power supply or to the negative terminal of the battery in your automobile.
- ( ) Connect the red battery clip to the positive (+) terminal of the power supply or to the positive terminal of the battery.
- ( ) Hold the pushbutton switch pressed in (a faint squealing sound is normal) and slowly rotate the 200  $\Omega$  control counterclockwise until the DC voltmeter reads 600 volts.
- ( ) Release the pushbutton switch and disconnect the battery clips. Also disconnect the DC voltmeter leads from the strobe tube at points L and K.
- ( ) Remove the rubber band or masking tape holding the trigger pickup cable and the power cord to the handle.

This completes the "Adjustments." Proceed to "Final Assembly."



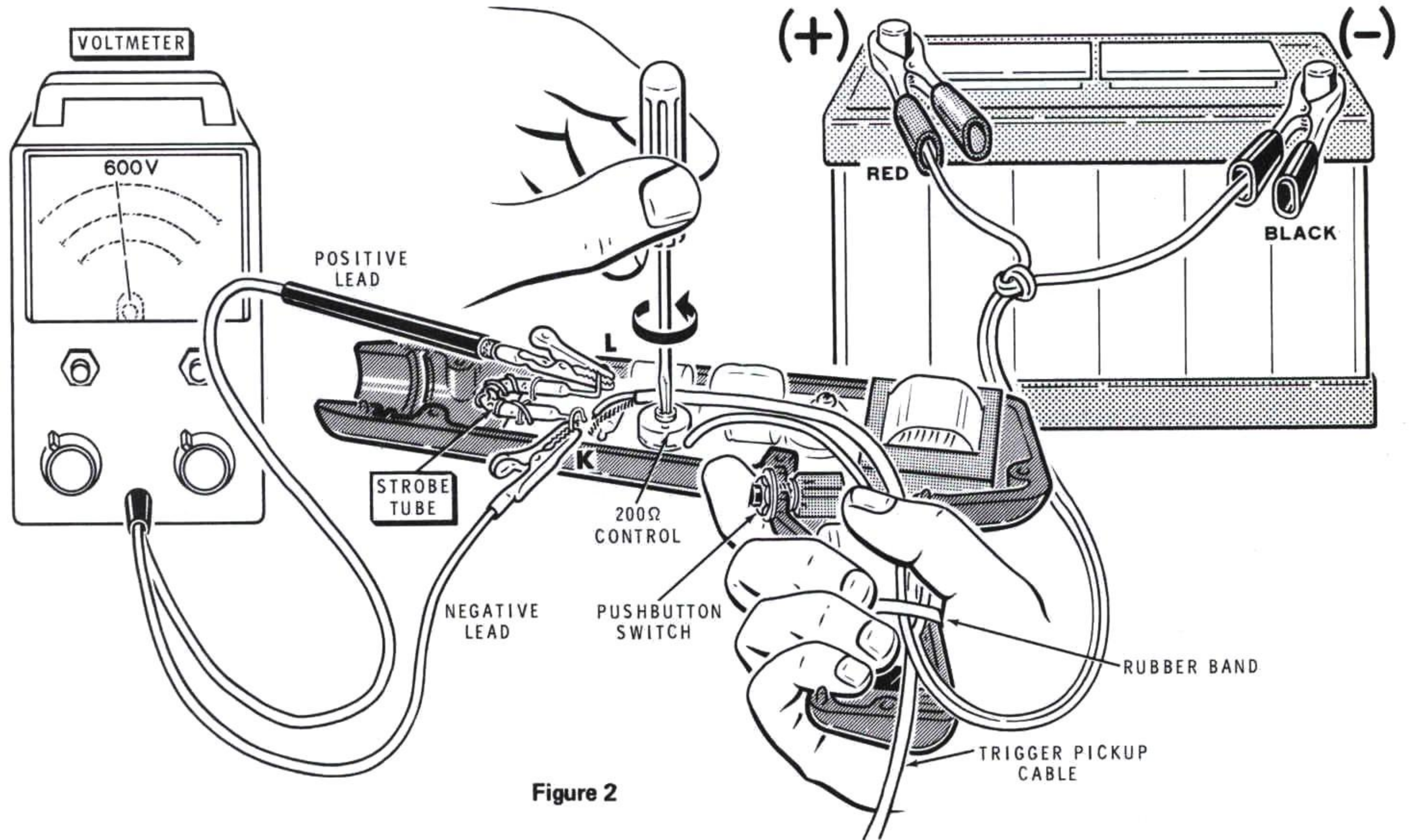



# FINAL ASSEMBLY

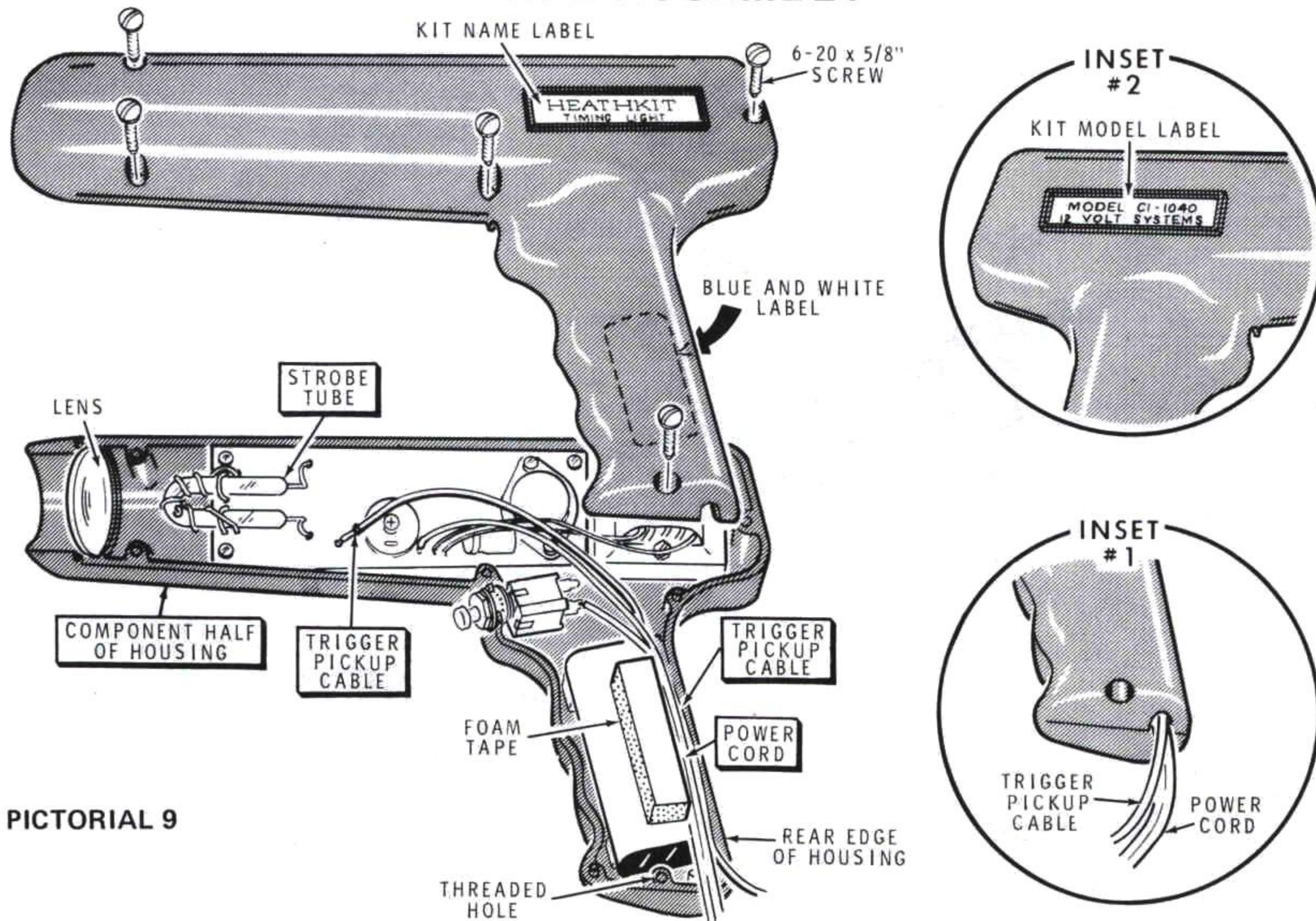

PICTORIAL 9



- ( ) Locate the blue and white label and the Registration Card. Then record the series number (printed on the blue and white label) in the proper place on the Registration Card.

Refer to Pictorial 9 for the following steps.

- ( ) Carefully peel away the backing paper from the blue and white identification label. Then press the label on the inside of the housing half at the location shown. Be sure to refer to the numbers on this label in any communications you have with the Heath Company about this kit.
- ( ) Peel the backing from only one side of the remaining length of foam tape. Press the tape onto the 2  $\mu$ F capacitor at the location shown.
- ( ) Place the lens in the component half of the housing with the flat side of the lens facing the strobe tube.
- ( ) Route the power cord and the trigger pickup cable past the pushbutton switch and the foam tape on the capacitor as shown. Locate the cord and the cable between the threaded hole in the handle and the rear edge of the housing.
- ( ) Route the green and black transformer wires over the 4  $\mu$ F electrolytic capacitor and away from the edge of the component housing. Then carefully place the housing half over the lens, the pushbutton switch, the power cord, and the trigger pickup cable.
- ( ) Position the power cord and the trigger pickup cable in the cutout of the housing half as shown in inset drawing #1. Be sure the housing half is positioned so it matches the component half before performing the next step.

- ( ) Install the five 6-20 x 5/8" screws in the housing half and carefully tighten them a few turns at a time. Do not overtighten the screws.
- ( ) Carefully remove the backing paper from the kit name label. Press the label in place in the recessed area of the barrel as shown.
- ( ) Carefully remove the backing from the kit model label. Press the label in place in the recessed area on the opposite side of the housing as shown in inset drawing #2.

NOTE: When not in use, wrap the power cord and high voltage cable in a "Figure 8" around the handle and barrel of the Timing Light as shown in Pictorial 10.

This completes the assembly of your Timing Light.

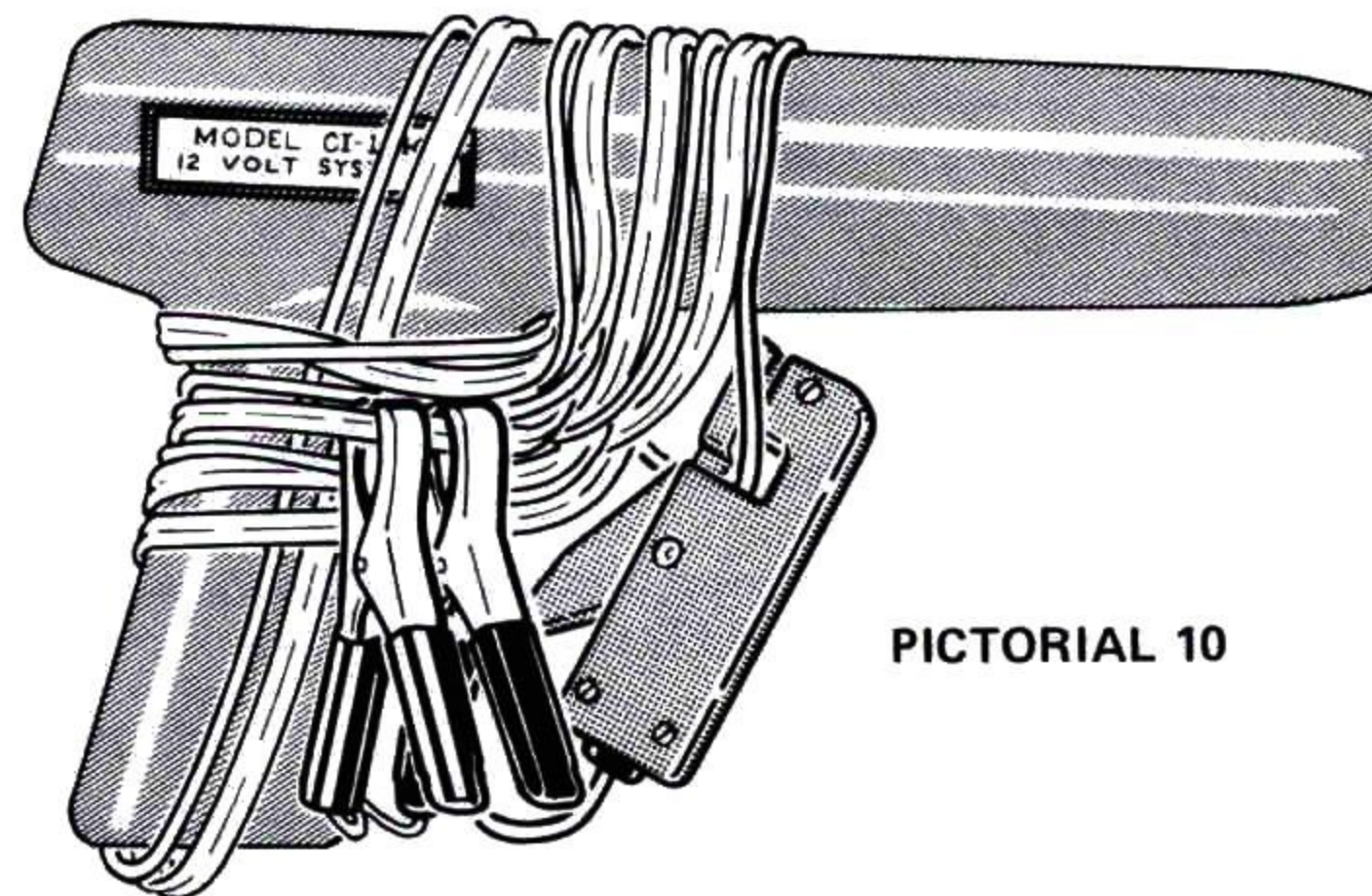

PICTORIAL 10



## OPERATION

Refer to Figure 3 (fold-out from Page 18) for an illustration of the operation and use of the Timing Light on an automobile engine.

**NOTE:** It may be helpful to refer to technical publications, books, and magazines for additional timing information and techniques.

### ENGINE TIMING SPECIFICATIONS

Obtain the timing specifications for your car's engine before attempting any timing adjustments.

If you wish, record your car's specifications on the "Engine Timing Specifications Chart" on the fold-out from Page 36.

### PRECAUTIONS

While doing engine timing, avoid personal injury or damage to the Timing Light, its power cord, and the trigger pickup lead by observing the following precautions:

1. Avoid touching any high voltage points on the engine ignition system.
2. Keep away from the fan and the fan belt.
3. Be sure the Timing Light, its power cord, and the trigger pickup cable are correctly positioned as shown in Figure 3 so they are clear of the fan and fan belt.
4. Avoid touching the exhaust manifold of the engine.

5. Do not lay the Timing Light on the engine.
6. Do not look directly at the lens of the Timing Light when it is operating.
7. Do not let the trigger clamp snap shut.

### OPERATING CONSIDERATIONS

The following considerations apply to using the Timing Light:

1. The Timing Light can be used in daylight at a range of up to two feet from the timing marks.
2. The pushbutton switch should not be taped down. Use the pushbutton switch only when doing timing adjustments or when checking the timing.
3. Do not attempt to do timing adjustments until other engine tuning work has been completed.
4. Operating the engine at over 2,000 rpm, with the Timing Light hooked up to the ignition system, will cause a loss of brightness in the Timing Light and cause its components to overheat. Operation of the Timing Light at engine speeds over 2,000 rpm should only be intermittent.
5. The Timing Light should not be used in temperatures below 0° F. The electronic components may be damaged.

### TIMING PROCEDURE EXAMPLE

Read through this section completely before attempting to time your engine.



Refer to Figure 4 (fold-out from this page) for an illustration of the hookup of the Timing Light to an automobile ignition system.

NOTE: The following basic step-by-step procedure is only an example.

1. Refer to the engine timing specifications.
2. Start the engine and allow it to warm up to normal operating temperature.
3. Use a tachometer to set the engine to the specified idle rpm.
4. Connect the trigger pickup around the #1 spark plug lead.
5. Connect the battery clip with black insulation to the negative (-) battery terminal. Connect the battery clip with red insulation to the positive (+) battery terminal. (DO NOT MAKE A CONNECTION TO THE COIL.)
6. Refer to the engine timing specifications for your particular engine and disconnect the vacuum line if required.

**WARNING:** The stroboscopic effect of the Timing Light that causes the timing mark to appear "stopped," also causes other revolving parts (fan, fan belt, and pulleys) to appear stopped. DO NOT place your hands near these supposedly "stopped" parts.

7. Aim the Timing Light at the timing marks and press the pushbutton switch.
8. If the timing reference mark lines up with the specified timing mark, no adjustment is necessary. Turn the engine off. However, if the reference mark does not line up with the timing mark, the engine needs timing. Proceed to step 9.
9. NOTE: Do not rotate the distributor after loosening the locking screw. (If you wish, mark the position of the distributor before loosening the screw so you can return it to the original adjustment point.)

Turn the engine off. Then carefully loosen the locking screw on the distributor clamp. Leave the screw tight enough so that the distributor will not change position by itself while the engine is running.

10. Start the engine.
11. Rotate the distributor until the timing reference mark lines up with the specified timing mark.
12. Tighten the distributor locking screw and then recheck the engine timing using the Timing Light.
13. NOTE: If the distributor of your engine has a centrifugal spark advance perform this step. If it does not have a centrifugal spark advance, disregard this step and proceed to step 14.

Increase the engine speed smoothly and observe the timing marks with the Timing Light aimed at them. The matching timing mark should move as the engine speed is increased. The direction of movement of the timing mark should be opposite to the direction of rotation of the damper pulley.

14. Reconnect the vacuum line if it was disconnected and plugged as required by the engine timing specifications.
15. Set the engine speed at higher than normal idle speed. While the Timing Light is aimed at the timing marks, open the throttle suddenly and then let it spring closed. The matching timing marks will momentarily move in the direction of rotation of the engine (retards spark) when the engine is suddenly speeded up. With normal speed increases, the vacuum control advances the spark and adds to the spark advance caused by the centrifugal advance mechanism. A sudden increase in engine speed causes the intake manifold vacuum to drop to a low value which momentarily retards the spark.

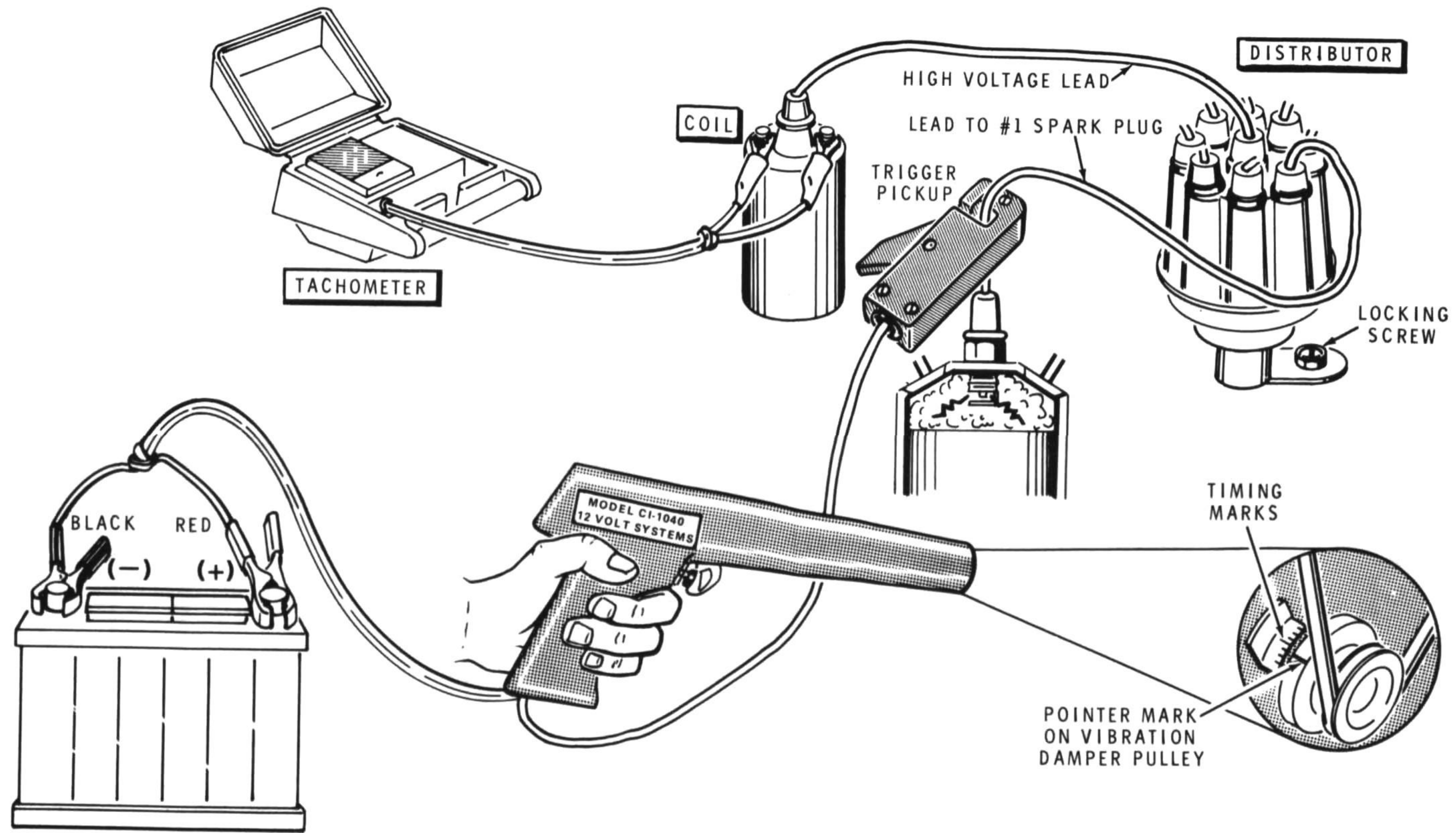

**Figure 4**



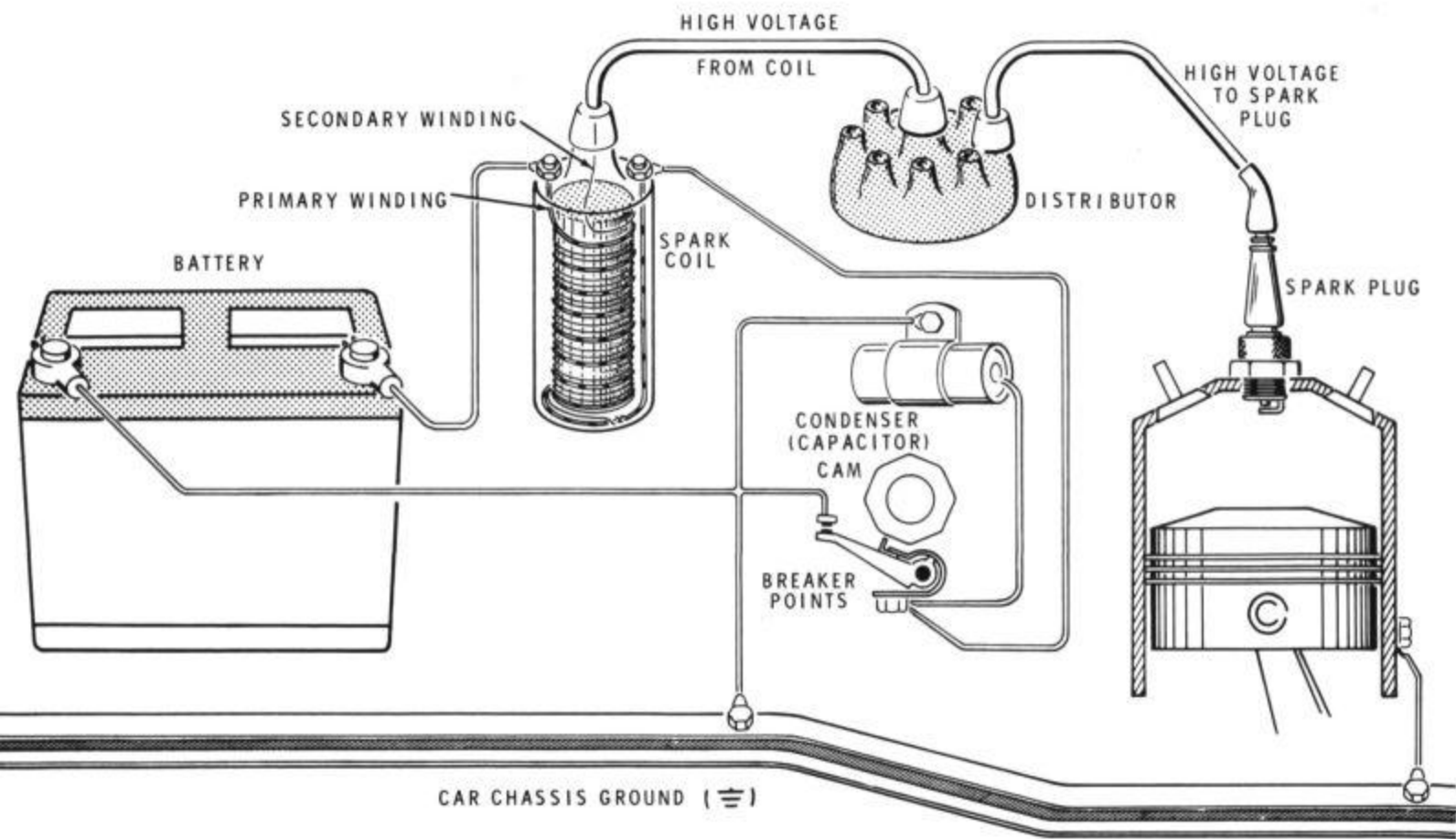

**Figure 8**

**PRINCIPLE OF OPERATION OF 4-CYCLE (STROKE) ENGINE**

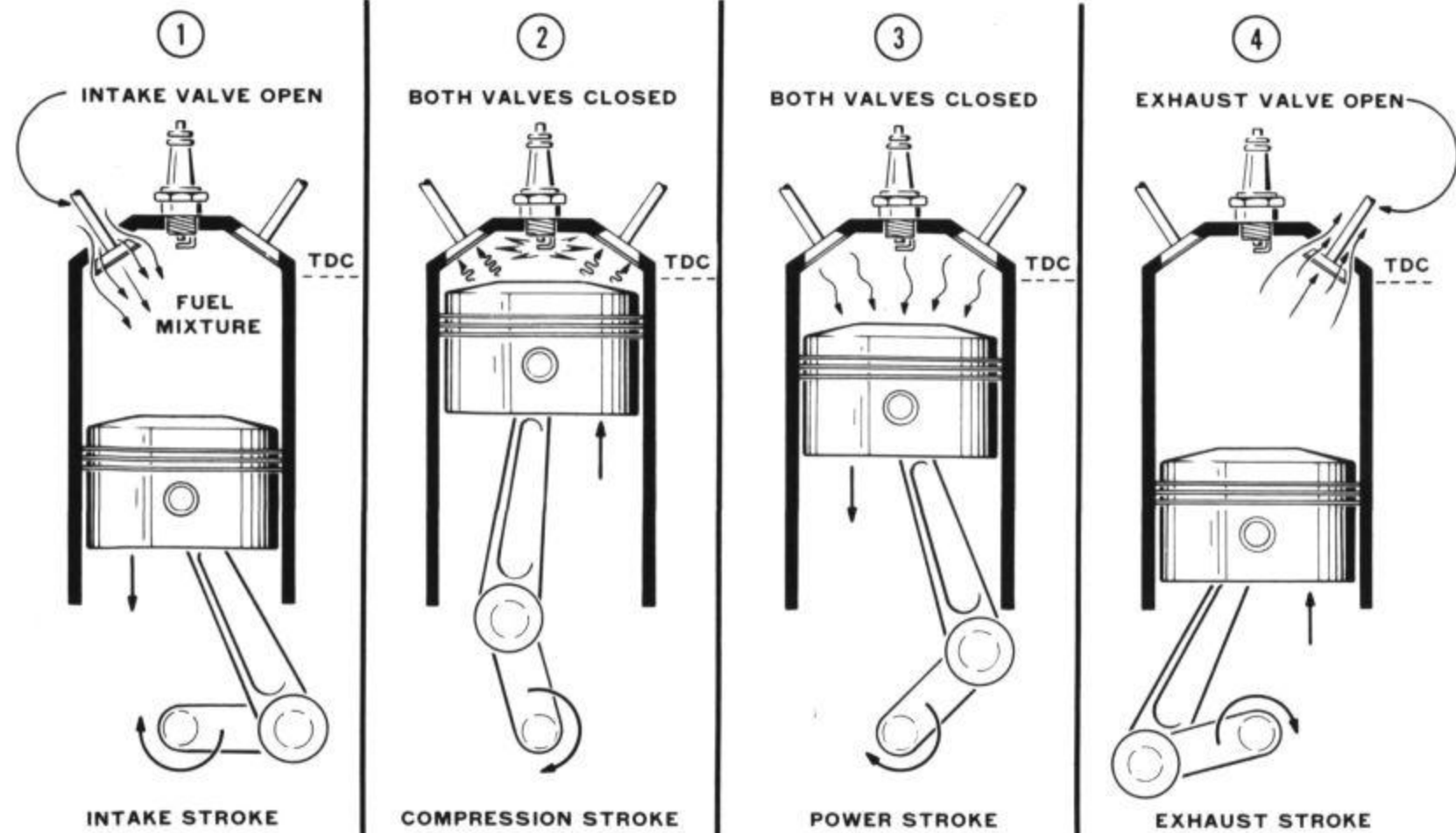

## IN CASE OF DIFFICULTY

Refer to the "Identification Photograph" on Page 36 and the "Circuit Board X-Ray View" on Page 35 for help in locating parts on the circuit board.

1. Recheck the wiring. Trace each lead in colored pencil on the Pictorial as it is checked. It is frequently helpful to have a friend check your work. Someone who is not familiar with the unit may notice something consistently overlooked by the builder.
2. About 90% of the kits that are returned for repair do not function properly due to poor connections and soldering. Therefore, many troubles can be eliminated by carefully checking all connections to make sure they are soldered as described in the "Soldering" section of the "Kit Builders Guide."
3. Check the values of the parts. Be sure that the proper parts have been wired into the circuits at each location.
4. Check electrolytic capacitors and diodes to be sure they are installed properly, with the marked end of each one positioned as it is shown in the Pictorial.

5. Check for bits of solder, wire ends, or other foreign matter which may be lodged in the wiring, or for solder bridges between foils on the circuit board.
6. Check the transistor and SCR with a transistor tester or by substitution of a transistor of the same type known to be good.
7. A review of the "Circuit Description" may also help you locate a difficulty.

NOTE: In an extreme case where you are unable to resolve a difficulty, refer to the "Customer Service" information inside the rear cover of the Manual. Your Warranty is located inside the front cover.

### TROUBLESHOOTING PROCEDURE

Difficulties with the Timing Light (see Troubleshooting Chart) are due to:  
1. The Timing Light, 2. The hookup to the ignition system, or 3. The engine or ignition system.

## Troubleshooting Chart

PROBLEM	POSSIBLE CAUSE
Strobe tube does not light (no squealing sound).	<ol style="list-style-type: none"> <li>1. Connections to battery.</li> <li>2. Oscillator transistor Q1.</li> <li>3. SW1.</li> </ol>



PROBLEM	POSSIBLE CAUSE
Strobe tube does not light (squealing sound can be heard).	<ol style="list-style-type: none"> <li>1. Incorrect connection to spark plug lead.</li> <li>2. Distributor lead broken or insulation on lead broken.</li> <li>3. #1 spark plug not firing. (Place the trigger pickup on another spark plug lead to check the strobe tube.)</li> <li>4. No voltage on strobe tube.</li> <li>5. SCR.</li> <li>6. Strobe tube faulty.</li> </ol>
Strobe tube lights only dimly.	<ol style="list-style-type: none"> <li>1. Low voltage to strobe tube (check R1 calibration control adjustment).</li> <li>2. Strobe tube faulty.</li> </ol>
Strobe tube flashes do not correspond to firing of #1 spark plug.	<ol style="list-style-type: none"> <li>1. Trigger pickup connected to incorrect spark plug lead and distributor lead. (Check the engine specifications for correct plug to be used in engine timing.)</li> </ol>
Strobe tube turns black or light is hard to see.	<ol style="list-style-type: none"> <li>1. Replace strobe tube.</li> </ol>

## SPECIFICATIONS

Useful Light Range . . . . .	Up to 2 feet in daylight.
Engine Speed Range . . . . .	Full flash brightness up to 2000 rpm. Operation above 2000 rpm should be intermittent only.
Triggering . . . . .	Current pickup coil.
Connecting Cables . . . . .	Battery cable with clips (7 feet). Trigger pickup cable with clip (5 feet).
Power Requirements . . . . .	12 volt automotive storage battery or separate 15 volt DC power supply with 1.5 ampere capacity.
Size . . . . .	6-1/2" high x 10" long x 2" wide.
Weight . . . . .	1 lb. 8 oz.

---

The Heath Company reserves the right to discontinue products and to change specifications at any time without incurring any obligation to incorporate new features in products previously sold.



# THEORY OF ENGINE OPERATION

## HOW TIMING WORKS

This section of the Manual explains the principles of operation of a 4-cycle engine (used in most automobiles). To understand how ignition timing works in an engine, read this section thoroughly.

Refer to Figure 5 (fold-out from Page 26) for an illustration of the basic principle of operation of a 4-cycle (4 strokes per cycle) engine. Only the #1 cylinder of the engine is shown. All the other cylinders of the engine operate in the same manner, going through the same four strokes per cycle as the #1 cylinder does. The sequence of operation of the other cylinders is determined by the engine design and by the firing order of the engine.

### ① Intake Stroke

On the intake stroke, the piston moves down, the exhaust valve closes, and the intake valve of the engine opens, admitting the fuel mixture to the engine.

### ② Compression Stroke

On the next stroke, the intake valve closes, and the piston moves up toward the head of the engine to compress the fuel mixture. At a certain "timed" instant, as the piston is still moving up, the spark plug fires and ignites the fuel. The distributor determines the timing of the spark.

### ③ Power Stroke

The fuel mixture, which has been ignited by the spark plug, requires approximately 1/350th of a second to burn completely. Depending on the speed at which the engine is operating, the fuel will still be burning for a certain amount of time after the piston reaches "top dead center" (TDC) and has started down on the power stroke. The force of expansion of the burning fuel pushes the piston down and gives the engine its power.

### ④ Exhaust Stroke

When the piston moves up again, the exhaust valve opens, releasing the burned fuel. This prepares the engine to take in fuel again for the intake stroke which follows the exhaust stroke.

## Top Dead Center

The crankshaft of the engine rotates through 180 degrees for each stroke of the piston. At the highest point of piston travel, the piston is at "top dead center" (TDC). All ignition timing, as specified by the engine manufacturer, is measured in degrees of crankshaft rotation from the point where the piston is at top dead center.

# ENGINE TIMING SETTINGS

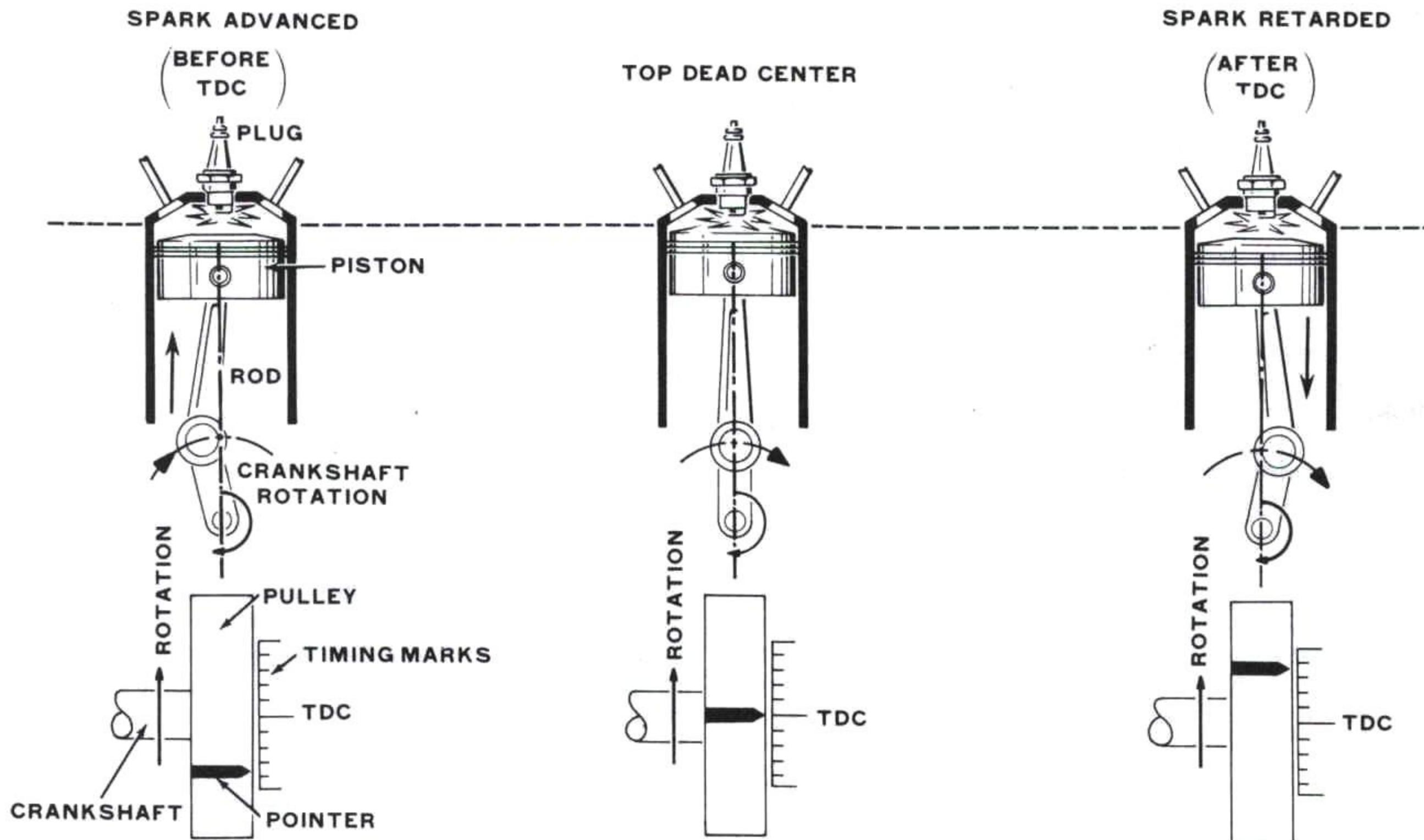

Figure 6



## Advancing or Retarding the Spark (Distributor Adjustment)

As shown in Figure 6, the time when the spark plug fires can be changed by manually adjusting the distributor. The terms "advanced" and "retarded" are used to designate the direction in which the spark timing is being changed. Causing the spark to occur at a point earlier in the rotation of the crankshaft is "advanced" and later is "retarded." The spark is advanced or retarded automatically by the centrifugal and automatic vacuum advance sections of the distributor. (See "Operation" on Page 24.) The centrifugal spark advance mechanism works from the speed of the engine. It advances the breaker cam of the distributor as the engine is speeded up. The automatic vacuum spark advance works from engine vacuum. It advances the distributor breaker plate with an increase in engine speed. When the throttle is opened suddenly, the vacuum spark control momentarily retards the spark to allow the engine to run smoothly.

## Using the Timing Marks on the Engine

Figure 7 shows example timing marks on an engine. These marks are calibrated to the angular rotation of the crankshaft relative to the position of the piston in the #1 cylinder before or after TDC. With the engine running, a timing light is aimed at the timing marks. Due to the stroboscopic effect, the pointer mark (or pointer) will appear to line up with one of the calibrated timing marks. The timing mark which matches the pointer mark indicates the position of the spark during the stroke of the piston in the #1 cylinder only.

## What the Timing Light Does

The strobe tube of the Timing Light is fired by the current induced into the trigger pickup coil when the #1 spark plug fires. The flash of the Timing Light illuminates the rotating damper pulley, and the timing marks, when the firing voltage for #1 spark plug occurs at the distributor as shown in Figure 8 (fold-out from Page 26). As the pulley passes the timing marks, the pointer or mark on the pulley will appear to align with one of the timing marks. If the engine needs timing, the distributor is adjusted (by rotating the distributor housing) so that the pulley mark then aligns with the proper timing mark as specified by the engine manufacturer. NOTE: On some engines, the timing marks are located on the vibration damper pulley and the reference mark is a stationary pointer located near the pulley.

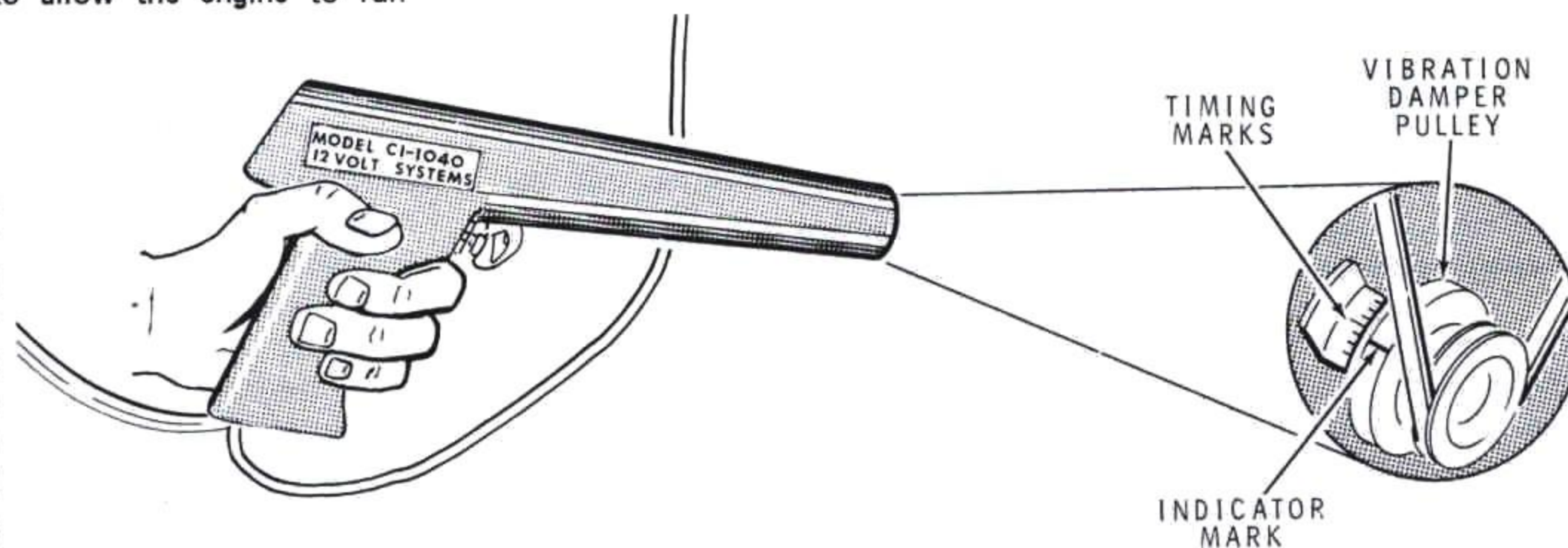

Figure 7



## CIRCUIT DESCRIPTION

Refer to the Block Diagram, and the Schematic (fold-out from Page 35) as you read the following descriptions.

### TIMING LIGHT

The voltage from the storage battery of the car is applied through switch SW1 to oscillator transistor Q1. R1, the 100  $\Omega$  control in the base circuit of Q1, varies the bias voltage of Q1. This bias voltage controls the oscillation frequency of Q1 and thus Q1's output, a pulsating dc to the primary winding of converter transformer T1, is controlled. This pulsating dc induces 600 volts AC in the secondary winding of T1.

The output voltage of T1 is applied to diodes D1 and D2, which operate as half-wave rectifiers and change the 600 volts AC to a pulsating DC voltage. The 2  $\mu$ F capacitor, C3, charges to the 600 volts, which is also applied to strobe tube V1. The tube does not fire at this time because the voltage is less than the self-ionization voltage of the tube. A voltage in the form of a trigger pulse is taken from the #1 spark plug lead of the engine when the plug fires.

A trigger pulse applied to the gate (G) of the SCR (D3) causes it to conduct. Capacitor C4 then discharges through trigger transformer L1. L1 steps up this voltage to the potential necessary to ionize the strobe tube. The tube then conducts, which allows capacitor C3 to discharge through the tube. A brilliant flash is produced that is approximately 10 microseconds in duration.

Resistors R4 and R5 form a voltage divider network for the voltage adjustment using the Neon lamp and control R1.

### AUTOMOTIVE IGNITION SYSTEM

As shown in Figure 8 (fold-out from Page 26), the ignition system of an automobile engine consists of the spark coil, the distributor, and the spark plugs. Voltage for the system is provided by the storage battery. This voltage is applied to one end of the primary (low voltage) winding of the spark coil. The primary winding is also connected to the breaker points of the distributor. A lead (high voltage) from the secondary winding of the spark coil is connected to the distributor rotor. From the distributor, individual high voltage leads connect to each of the spark plugs of the engine.

When the distributor breaker points are closed, current flows through the points and the primary of the ignition coil. This causes a magnetic field to build up in the coil. Then, as the points are opened (by the distributor shaft cam), the current stops flowing and the magnetic field collapses — creating a high voltage (approximately 20,000 volts) in the secondary winding of the coil. This voltage is conducted to the spark plugs through the distributor rotor and distributor leads. The specific timing (instant the plug fires) is set by adjusting the distributor. The Timing Light is used to stroboscopically illuminate the timing marks (scale of degrees) on the engine and thus to determine accurately the angular position of the crankshaft when the spark plug fires. Engine timing specifications state at what position (in degrees of rotation relative to TDC) the spark plug should fire for proper timing.



### BLOCK DIAGRAM OF TIMING LIGHT CIRCUIT

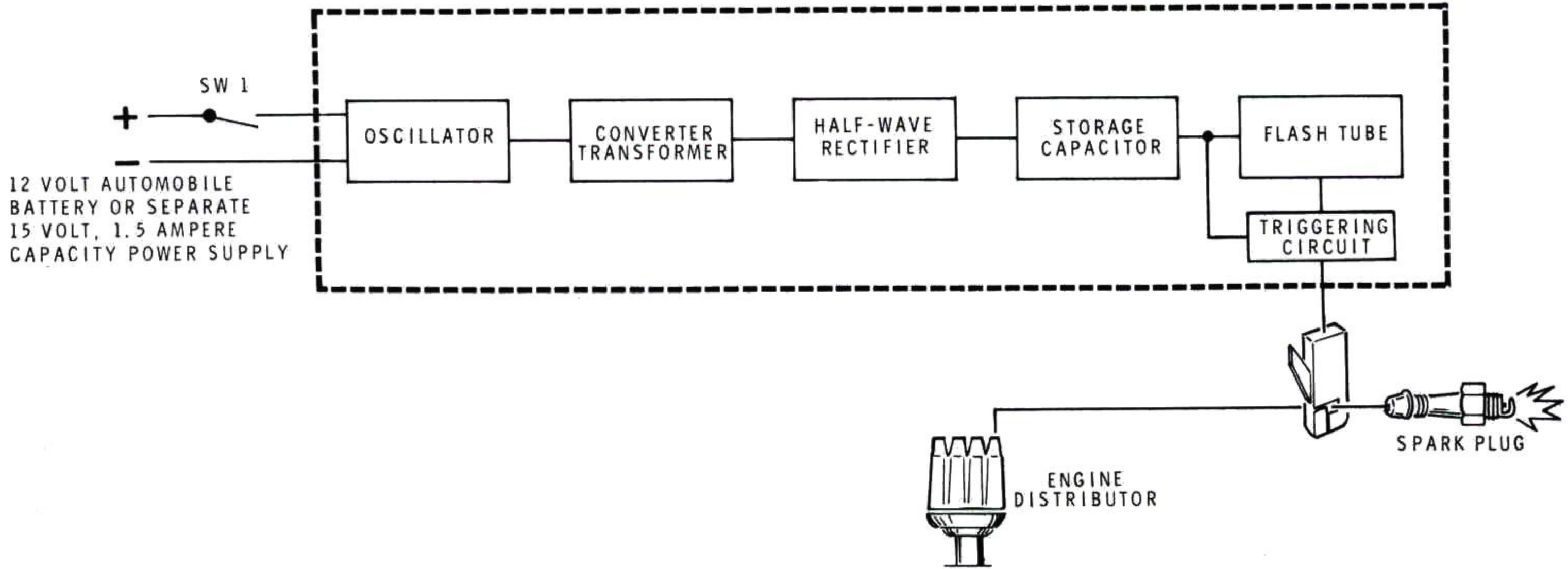





## CIRCUIT BOARD X-RAY VIEW

NOTE: To determine the value ( $22\ \Omega$ ,  $4\ \mu\text{F}$ , etc.) of one of these parts, you may proceed in either of the following ways.

1. Refer to the place where the part is installed in the Step-by-Step instructions.
2. Note the identification number of the part (R-number, C-number, etc.). Then locate the same identification number next to the part on the Schematic. The value, or "Description," of most parts will be near this number.

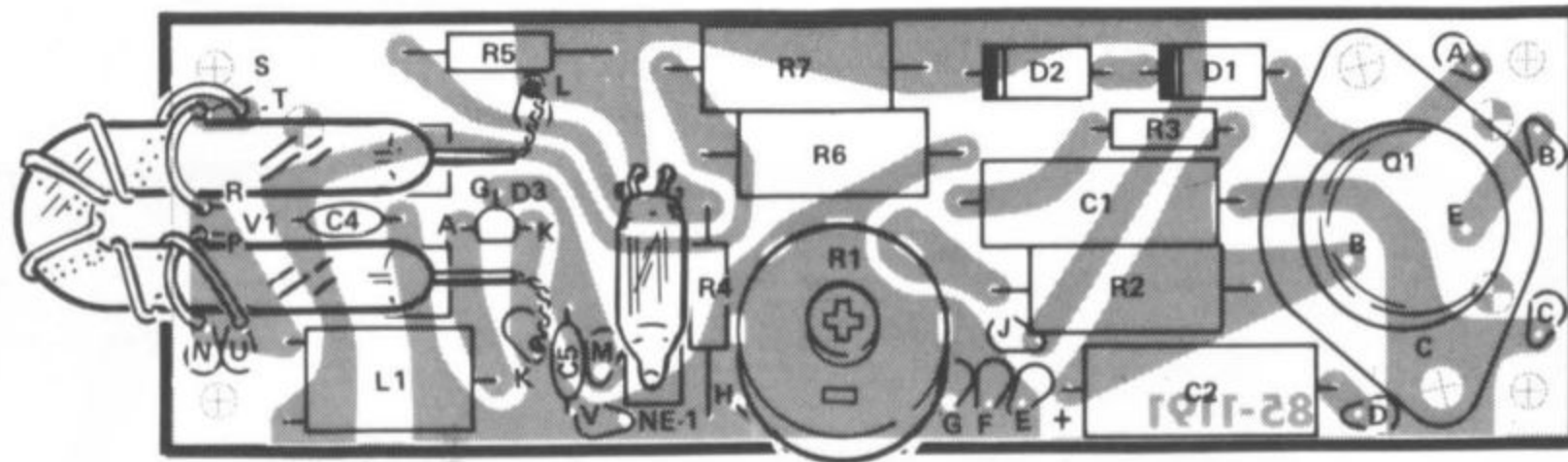

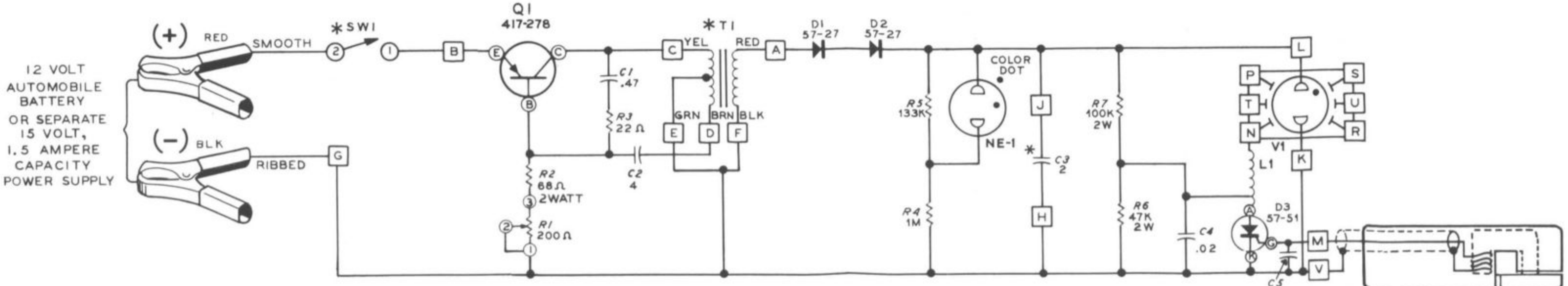

12 VOLT  
AUTOMOBILE  
BATTERY  
OR SEPARATE  
15 VOLT,  
1.5 AMPERE  
CAPACITY  
POWER SUPPLY

BASING DIAGRAM  
(BOTTOM VIEW)

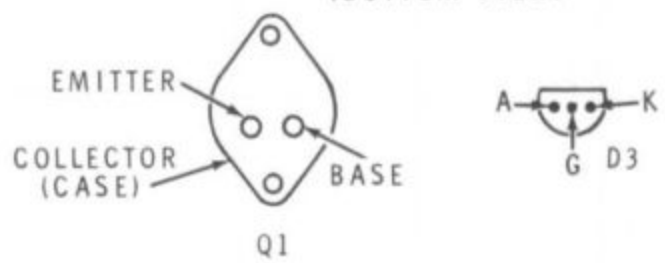

**SCHEMATIC OF THE  
HEATHKIT®  
12-VOLT AUTOMOTIVE  
DELUXE TIMING LIGHT  
MODEL CI-1040**

**SCHEMATIC NOTES:**

1. RESISTOR VALUES ARE IN OHMS (K=1000). RESISTORS ARE 1/2 WATT UNLESS OTHERWISE SPECIFIED.
2. ALL CAPACITOR VALUES ARE IN μF.
3. □ THIS SYMBOL INDICATES CONNECTION TO CIRCUIT BOARD.
4. \* ITEMS NOT ON CIRCUIT BOARD.

L2\*  
TRIGGER  
PICKUP COIL



# ENGINE TIMING SPECIFICATIONS CHART

CAR			IGNITION TIMING			DEGREES PER TIMING MARK	VACUUM SPARK ADVANCE LINE DISCONNECTED		IDLE SPEED (RPM)	TRANSMISSION SELECTOR		LOCATION OF #1 SPARK PLUG
YR.	MAKE	MODEL AND ENGINE	° BTDC <sub>1</sub>	TDC <sub>2</sub>	° ATDC <sub>3</sub>		YES	NO		NEUTRAL	DRIVE	

1. BTDC = BEFORE TOP DEAD CENTER
2. TDC = TOP DEAD CENTER (Highest point of piston travel in cylinder).
3. ATDC = AFTER TOP DEAD CENTER

**OTHER SPECIFICATIONS** \_\_\_\_\_  
 \_\_\_\_\_

**NOTES** \_\_\_\_\_  
 \_\_\_\_\_  
 \_\_\_\_\_  
 \_\_\_\_\_

# IDENTIFICATION PHOTOGRAPH

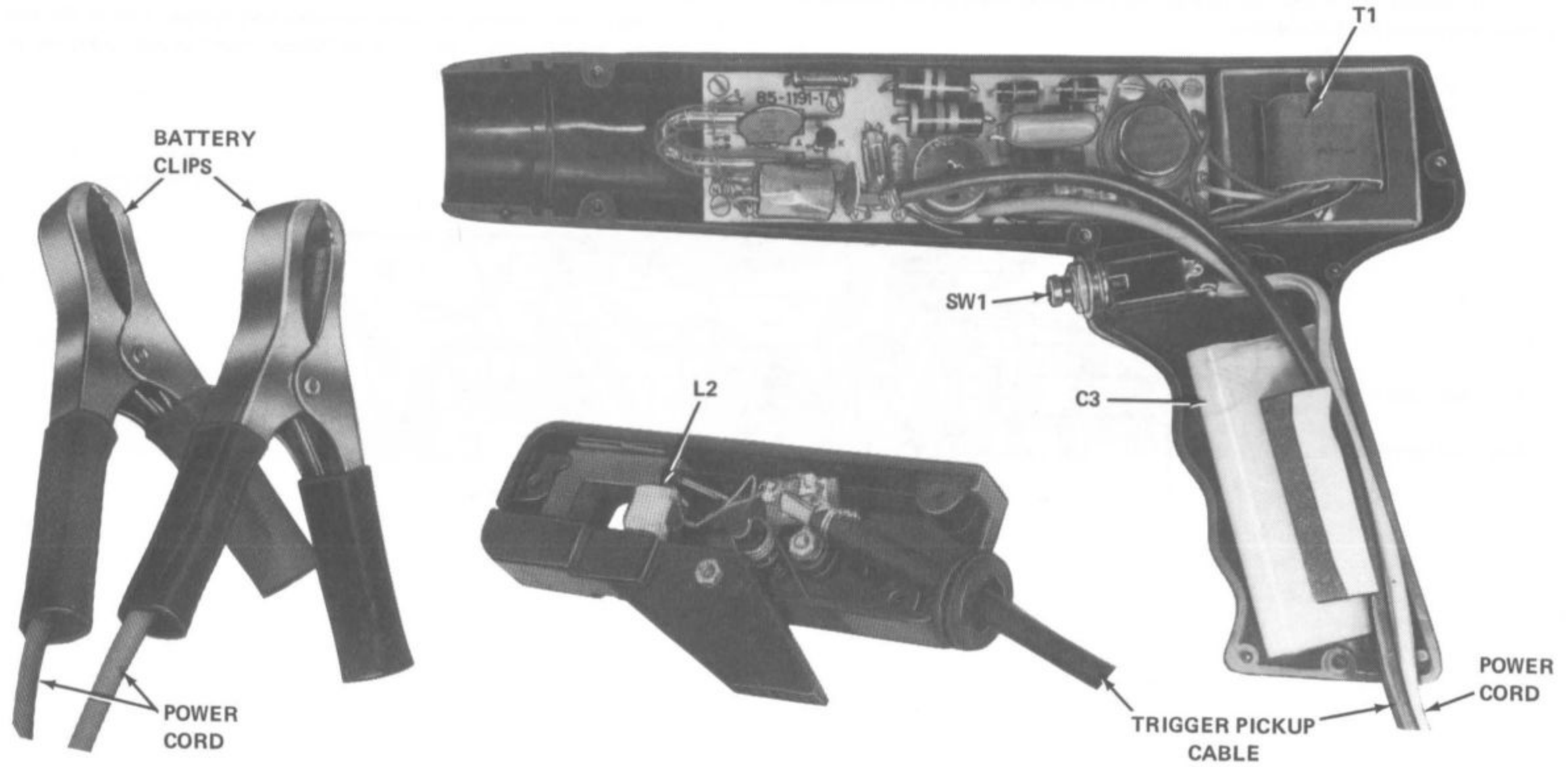



# CUSTOMER SERVICE

## REPLACEMENT PARTS

If you need a replacement part, please fill in the Parts Order Form that is furnished and mail it to the Heath Company. Or, if you write a letter, include the:

- Part number and description as shown in the Parts List.
- Model number and Series number from the blue and white label.
- Date of purchase.
- Nature of the defect.

**Please do not return parts** to the factory unless they are requested. Parts that are damaged through carelessness or misuse by the kit builder will not be replaced without cost, and will not be considered in warranty.

Parts are also available at the Heathkit Electronic Centers listed in your catalog. Be sure to provide the Heath part number. Bring in the original part when you request a warranty replacement from a Heathkit Electronic Center.

NOTE: Replacement parts are maintained specifically to repair Heathkit products. Parts sales for other reasons will be declined.

## TECHNICAL CONSULTATION

Need help with your kit? . . . . Self-Service? . . . . Construction? . . . . Operation? . . . . Call or write for assistance. You'll find our Technical Consultants eager to help with just about any technical problem except "customizing" for unique applications.

The effectiveness of our consultation service depends on the information you furnish. Be sure to tell us:

- The Model number and Series number from the blue and white label.
- The date of purchase.
- An exact description of the difficulty.
- Everything you have done in attempting to correct the problem.

Also include switch positions, connections to other units, operating procedures, voltage readings, and any other information you think might be helpful.

**Please do not send parts for testing**, unless this is specifically requested by our Consultants.

Hints: Telephone traffic is lightest at midweek. . . please be sure your Manual and notes are on hand when you call.

Heathkit Electronic Center facilities are also available for telephone or "walk-in" personal assistance.

## REPAIR SERVICE

Service facilities are available, if they are needed, to repair your completed kit. (Kits that have been modified, soldered with paste flux or acid core solder, cannot be accepted for repair.)

**If it is convenient, personally deliver your kit to a Heathkit Electronic Center. For warranty parts replacement, supply a copy of the invoice or sales slip.**

If you prefer to ship your kit to the factory, attach a letter containing the following information directly to the unit:

- Your name and address.
- Date of purchase.
- Copies of all correspondence relevant to the service of the kit.
- A brief description of the difficulty.
- Authorization to return your kit C.O.D. for the service and shipping charges. (This will reduce the possibility of delay.)

Check the equipment to see that all screws and parts are secured. (Do not include any wooden cabinets or color television picture tubes, as these are easily damaged in shipment.) Place the equipment in a strong carton with at least **THREE INCHES** of *resilient* packing material (shredded paper, excelsior, etc.) on all sides. Use additional packing material where there are protrusions (control sticks, large knobs, etc.). If the unit weighs over 15 lbs., place this carton in another one with 3/4" of packing material between the two.

Seal the carton with reinforced gummed tape, tie it with a strong cord, and mark it "Fragile" on at least two sides. Remember, the carrier will not accept liability for shipping damage if the unit is insufficiently packed. Ship by prepaid express, United Parcel Service, or insured Parcel Post to:

Heath Company  
Service Department  
Benton Harbor, Michigan 49022





HEATH COMPANY • BENTON HARBOR, MICHIGAN

**THE WORLD'S FINEST ELECTRONIC EQUIPMENT IN KIT FORM**

LITHO IN U.S.A.